

C | D | A

Built for your life



Appliances • Sinks • Taps
April 2018



Why choose CDA?



ISO9001 accredited



FS 532687

CDA have achieved ISO9001 accreditation, recognising our commitment to continuous improvement.

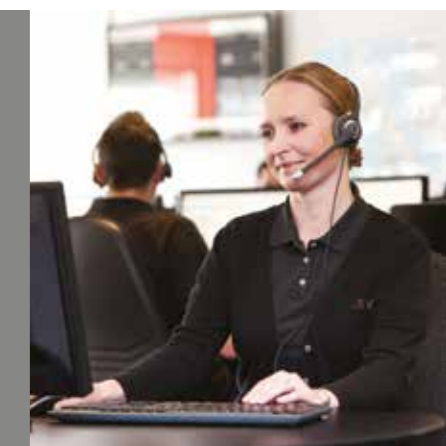

Our assurance of quality

Our on-site testing laboratory ensures that only safe, reliable products are brought to market. We test to the British consumers' exacting standards without compromise.

Dedicated engineers

We use our own dedicated service engineers, equipped with a large range of CDA spare parts allowing them to achieve an excellent first time fix rate.

In-house Customer Care Department

Our in-house Customer Care Department, based at our head office in Nottinghamshire, is made up of highly knowledgeable and experienced staff who will support you throughout the lifetime of your product.

Over 25 years experience

Established for over 25 years, CDA have built a reputation for stylish, innovative and award winning products that consistently deliver outstanding results.

More deliveries to you

CDA delivers to retailers & kitchen studios daily so your new appliances will arrive quickly. All of our stock is held between our 9 acre site in Nottinghamshire and an additional warehouse in Newton. These central locations are ideally located to ensure efficient and fast distribution across the UK.

Part of the Amica group PLC

In December 2015, CDA became part of the Amica Group.

Amica, a kitchen appliance manufacturer based in Poland, operate in 50 countries worldwide and have over 70 years' experience in the industry.

CDA share the same vision of providing the best products possible, as well as our values of good environmental practice, and together we will deliver even more for customers.



Our guarantee

All CDA appliances are covered by a 5 year parts and 2 year labour guarantee for complete peace of mind.



“Quality is something we respect and strive for in our products, our people and our service. Our reputation is built on delivering genuine quality through those three foundations every single day.”

Ian

Ian Kershaw
CDA founder and Chairman

COOKING

Freestanding cookers	10
Range cookers	18
Single ovens	28
Compacts	40
Double ovens	52
Hobs	62
Extractors	88

COOLING

Refrigeration	116
Wine coolers	136

WASHING

Dishwashers	146
Laundry	154

SINKS & TAPS

Sinks	162
Taps	196
Accessories	210-218

Oven functions explained



Oven light

This illuminates the oven cavity for easy viewing of food during cooking.



Defrost

Using the fan only, this oven function circulates the air around the oven cavity, speeding up the natural defrosting process.



Conventional oven/
Eco conventional oven

This function uses the top and bottom heating elements only. Natural convection creates a perfect cooking zone in the centre of the oven, ideal for dark fruit cakes and pastries.

The Eco setting on the fan oven or conventional oven uses residual heat to finish cooking your meal, saving energy.



Fan-assisted oven

Using the fan to circulate the heat produced by the top and bottom heating elements, this function distributes the heat around the oven to give an even temperature throughout.



Fan oven/Eco fan oven

Using the circular heating element and the fan, this cooking function circulates heated air around the oven cavity; temperatures are achieved quickly reducing the need for preheating. Both cooking temperature and cooking time can be reduced for a more energy efficient cooking programme. This is perfect for cooking various food types simultaneously as foods are sealed quickly to prevent flavour transfer.

The Eco setting on the fan oven or conventional oven uses residual heat to finish cooking your meal, saving energy.



Fan cooking with lower heat

Using the fan element to enhance the main heat being produced by the lower heating element, this function is perfect for cooking pizzas.



Fan cooking with upper heat

Uses the fan element and the top element to create a gentle heat, ideal for reheating already cooked foods or keeping food warm.



Fan with lower heat

The fan circulates the heat produced by the bottom heating element, ideal for one pot dishes such as casseroles or curries.



Browning oven

The perfect finishing touch, using the top element only this function browns and crisps food with conventional heat. This is ideal for cauliflower or macaroni cheese.



Warming oven

Using heat produced only by the bottom element, this natural heat is perfect for dough proving and blind baking.



Eco clean/Aqualytic cleaning

The Eco setting creates hot steam from water in the oven tray to loosen dirt and grease.

The Aqualytic cleaning function uses water to steam clean the interior of your oven, loosening grease and dirt from the enamel.



Full grill/Half grill/ Turbo grill

This fully variable grill is ideal for grilling a full family meal.

Some ovens offer a half grill option, using just the centre section for grilling smaller quantities.

The turbo grill reaches higher temperatures than a standard grill, ideal for finishing off a crème brulee topping for example.



Fanned electric grill/
Half fanned electric grill

This uses the grill element and the fan to circulate the heat around the food.

Some ovens offer a half fanned grill option, using just the centre section for grilling smaller quantities.



Rotisserie electric

Using the grill element, heat is radiated down on to food which is rotating on the rotisserie aiding even browning.



Rotisserie fanned grill

For fast, even cooking, the fan circulates the grill heat around the food as it turns on the rotisserie, creating a perfect crispy finish.



Rotisserie conventional

Using both the top and bottom elements ensures even cooking when using the rotisserie, ideal for pork, chicken and beef.



Steam oven

Cooking with the power of steam alone locks more nutrients into your food. Steaming is the healthier option for cooking meat, fish, vegetables and fruits.



Pyrolytic cleaning

This function raises the temperature of your oven to 450°C, reducing any food deposits to a fine ash which can then be easily wiped away from the oven interior.

Full pyrolytic clean - 2 hours.



Gas oven

Heat rises from the gas burner at the base of the oven. This method of cooking (hot at the bottom, cooler at the top) is perfect for family meals, as foods can be cooked at different temperatures at the same time.



Gas grill

This variable gas grill is used with the door ajar, giving you perfect results when grilling chops, burgers and sausages.



Rotisserie gas

Our gas range cooker offers a rotisserie option, using either the grill or oven.



Fanned gas oven

Heat rises from the gas burner at the base of the oven and is distributed by a fan, creating an even cooking temperature.



Microwave function

Food is cooked from the outside in using microwaves, making this style of cooking quick and convenient.



Microwave and grill

Food is cooked from the outside in using microwaves with the added feature of the grill browning the food.



Microwave and fan oven

Food is cooked using microwaves and browned on the outside by the fan oven.



Microwave, grill and fan oven

This function combines the microwave function and the fan oven to cook food thoroughly and brown the top for a perfect oven finish.

Freestanding cookers

Our contemporary freestanding cookers are designed to be beautiful in both form and function.



Whether you are looking for all gas, all electric or a combination of both we have a stylish and practical collection of models for you to choose from.

Freestanding cookers

Every cooker in the range features something 'extra'. From the dual zone cooking on our all electric ceramic model and the power boosters on the configurable induction hob, to the wok burners and cast iron pan supports on the gas hobs, we have designed these models to take expectations of freestanding cooking to the next level.



Gas models

Cooking on gas is fast and responsive. If you are looking for a gas oven and gas hob, the CFG610 is an ideal freestanding cooker for your kitchen. Featuring all the standard safety and automatic ignition elements that you would expect from a CDA gas hob this model also comes with cast iron pan supports as standard. There is a wok burner to take you from every day cooking to a theatrical cooking experience and the unit is conveniently sized to be installed in just a 60cm width space.

Too often the top ovens are small enough for grilling but with not enough room to cook properly. At 44L (21L in the gas model) these ovens offer space to use the second oven as a viable and useful cooking cavity.

Combining the best of both gas and electric, the CFD650 is a double cavity, freestanding cooker with a 4 burner gas on glass hob and electric ovens. You can enjoy reliable, controllable electric oven cooking in either cavity, prepare multiple courses simultaneously and cook quickly and easily on the gas hob, finished with stylish cast iron pan supports.

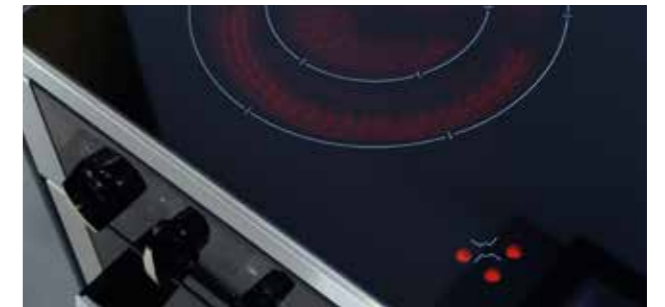

Ceramic model

For practical, easy to clean cooking the ceramic hob and electric oven CFC630 cooker is perfect. It comes with a shatterproof Schott Ceran™ glass hob surface that is easy to wipe clean and a dual zone front cooking zone that can accommodate larger cookware. It is an extremely stable material that is resistant against abrupt temperature changes. It is also designed to withstand daily wear and tear that can occur in the kitchen whilst cooking. The four millimetre thick glass is extremely heat permeable. The glass is able to transfer heat quickly and efficiently so that it is transmitted directly to the pots and pans, keeping the rest of the hob relatively cool. This makes it both safe and energy efficient. Ceramic glass is suitable for all kinds of heating technologies - ceramic, induction and gas.



Induction model

If you are looking for all electric cooking there is a choice between radiant ceramic heat and rapid, energy efficient induction hob cooking, with both models featuring large cavity main ovens plus an extra conventional oven cavity and grill.

Induction cooking is fast, efficient and clean with an easily wipeable surface made from Schott Ceran™ ceramic glass. The technology on the CFN670 induction cooker is easy to use with a touch control panel on the hob surface that declutters the front of your cooker. There are 4 power boosters for rapid boiling and frying and extra features including a keylock for safety and keep warm functions to get more from your cooking. The specific requirement for cooking on an induction hob is that only ferromagnetic pans will work (a magnet will stick to the base of the pan if it is compatible with induction hobs). High quality, flat based pans work best with induction and new pans will carry this symbol on the packaging to show they can be used:

Quick guide to freestanding cookers

Our range of freestanding cookers offer flexible installation and capable cooking technology. There are options to cover every fuel type from a gas hob & gas oven model to all electric or a combination gas hob, electric oven cooker. We've included extra features throughout the range to enhance the cookers from cast iron pan supports to large cavity ovens and dual zone cooking.

Gas



CFG610

- 60cm double cavity freestanding cooker, gas ovens, gas hob
 - 2/2 functions
 - Touch control programmer
- More details on p14

Gas



CFD650

- 60cm double cavity freestanding cooker, electric ovens, gas hob
 - 3/5 functions
 - Touch control programmer
- More details on p15

Ceramic



CFC630

- 60cm double cavity freestanding cooker, electric ovens, ceramic hob
 - 3/5 functions
 - Touch control programmer
- More details on p16

Induction



CFN670

- 60cm double cavity freestanding cooker, electric ovens, induction hob
 - 3/5 functions
 - Touch control programmer
- More details on p17



CFG610
60cm double cavity freestanding cooker,
gas ovens, gas on glass hob

Main oven



Second oven



Hob features

- 4 burners
- Automatic ignition
- Cast iron pan supports
- Flame failure safety device included
- Wok burner

Oven features

- Easy clean enamel interior
- Cooling fan
- Interior lights
- Chromed rack sides with integrated anti-tilt shelves
- Touch control programmable electronic clock/timer
- Double glazed door with removable inner door glass for easy cleaning
- Removable doors
- Main oven door side opening

Accessories

- Cast iron wok support
- 2 flat oven shelves
- 1 grill pan with grid
- 1 grill pan handle
- LPG conversion kit included

Available in

- Stainless steel

Hob specification

- Front left, triple ring/wok: 3kW
- Front right, semi-rapid: 1.75kW
- Rear left, semi-rapid: 1.75kW
- Rear right, rapid: 3kW

Technical specification

- Main oven useable capacity: 44L
- Second oven useable capacity: 21L
- Rated gas input: 16.4kW
- Rated electrical power: 0.7VA
- Power supply required: 3A

Energy efficiency rating

- Energy rating (main oven): A
- Energy rating (second oven): A

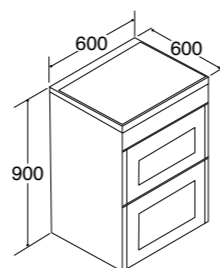

CFD650
60cm double cavity freestanding cooker,
electric ovens, gas on glass hob

Main oven



Second oven



Hob features

- 4 burners
- Automatic ignition
- Cast iron pan supports
- Flame failure safety device included
- Wok burner

Oven features

- Easy clean enamel interior
- Cooling fan
- Interior lights
- Chromed rack sides with integrated anti-tilt shelves
- Touch control programmable electronic clock/timer
- Double glazed door with removable inner door glass for easy cleaning
- Removable doors
- Main oven door side opening

Accessories

- Cast iron wok support
- 2 flat oven shelves
- 1 spacesaver shelf
- 1 grill pan with grid
- 1 grill pan handle
- LPG conversion kit included

Available in

- Stainless steel

Hob specification

- Front left, triple ring/wok: 3kW
- Front right, semi-rapid: 1.75kW
- Rear left, semi-rapid: 1.75kW
- Rear right, rapid: 3kW

Technical specification

- Main oven useable capacity: 67L
- Second oven useable capacity: 44L
- Rated gas input: 9.5kW
- Rated electrical power: 4.5kW
- Power supply required: 20A

Energy efficiency rating

- Energy rating (main oven): A
- Energy rating (second oven): A

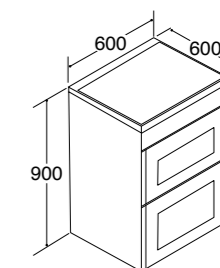



CFC630
60cm double cavity freestanding cooker, electric ovens, ceramic hob

Main oven



Second oven



Hob features

- 4 zones
- 6 power levels
- Easy clean surface
- Ceramic shatterproof safety glass
- Residual heat indicators
- Temperature limiter

Oven features

- Easy clean enamel interior
- Cooling fan
- Interior lights
- Chromed rack sides with integrated anti-tilt shelves
- Touch control programmable electronic clock/timer
- Double glazed door with removable inner door glass for easy cleaning
- Removable doors
- Main oven door side opening

Accessories

- 2 flat oven shelves
- 1 spacesaver shelf
- 1 grill pan with grid
- 1 grill pan handle
- Available in
- Stainless steel

Hob specification

- Front left: – 120mm: 0.75kW
- 120mm: 2.2kW
- Front right, 145mm: 1.2kW
- Rear left, 145mm: 1.2kW
- Rear right, 180mm: 1.8kW

Technical specification

- Main oven useable capacity: 67L
- Second oven useable capacity: 44L
- Rated electrical power: 10.9kW
- Power supply required: 45A

Energy efficiency rating

- Energy rating (main oven): A
- Energy rating (second oven): A

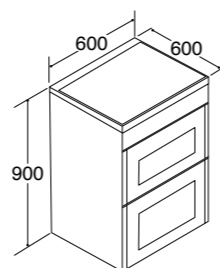

CFN670
60cm double cavity freestanding cooker, electric ovens, induction hob

Main oven



Second oven



Hob features

- 4 zones
- Electronic touch control
- 9 power levels
- Booster function on all zones
- Easy clean surface
- Ceramic shatterproof safety glass
- Residual heat indicators
- 99 minute timer
- Keep warm function
- LED display
- Safety key lock
- Overflow detection
- Overheat detection
- Automatic pan detection
- Small object detection
- Auto safety switch off
- Time limit security system
- Temperature limiter

Oven features

- Easy clean enamel interior
- Cooling fan
- Interior lights

- Chromed rack sides with integrated anti-tilt shelves
- Touch control programmable electronic clock/timer
- Double glazed door with removable inner door glass for easy cleaning
- Removable doors
- Main oven door side opening

Accessories

- 2 flat oven shelves
- 1 spacesaver shelf
- 1 grill pan with grid
- 1 grill pan handle

- Available in
- Stainless steel

Hob specification

- Front left, 210mm: 2kW , 2.8kW with booster

- Front right, 160mm: 1.2kW, 1.4kW with booster
- Rear left, 160mm: 1.2kW, 1.4kW with booster
- Rear right, 210mm: 2kW , 2.8kW with booster

Technical specification

- Main oven useable capacity: 67L
- Second oven useable capacity: 44L
- Rated electrical power: 7.3 - 11.9kW (hob configurable)
- Power supply required: 32 - 45A

Energy efficiency rating

- Energy rating (main oven): A
- Energy rating (second oven): A

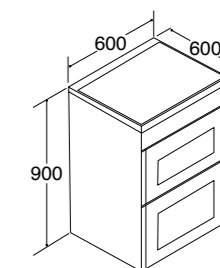



Range cookers

Our contemporary range cookers are designed to be beautiful in both form and function.

All electric, all gas or the best of both with a professional style gas hob and multifunction electric ovens. There is a choice to suit every cook in any kitchen.



Multi-function

Every range cooker in the collection has been designed to combine good looks with outstanding performance. Our multi-function cooking technology has been applied to the range cookers to offer you flexible cooking styles and functions and make them truly capable cooking workstations.

90cm traditional range cookers

Our 90cm traditional range cookers offer a more classic aesthetic in a choice of cream or black. Both models are a dual fuel configuration with triple oven cavities and come with a built in rear back guard.



Useful accessories

Useful accessories such as plate warmer racks and space saver shelves make CDA range cookers the perfect choice for keen cooks. There are telescopic shelves to help with getting food in and out of the oven safely and catalytic liners that will keep your oven cavities cleaner, cutting down on maintenance and cleaning time.

The RV1200 range cooker comes with an aluminium pastry plate, as shown below. Please see the accessory section for our full range of optional accessories.



Quick guide to range cookers

Our collection of range cookers offers a wide variety of sizes and configurations:

- All gas, all electric or dual fuel models available
- Sizes from 90cm to 120cm wide
- One, two or three oven cavities
- Five or six hob burners or zones, with an additional griddle plate hob available

90cm wide



RVC931

- Dual fuel
 - 5 burner gas hob
 - Triple cavity ovens, 8/3/2 functions
 - Available in cream or black
- More details on p22

90cm wide



RV911

- Dual fuel
 - 5 burner gas hob
 - Single cavity oven, 8 functions
 - Stainless steel
- More details on p23



RV921

- Dual fuel
 - 5 burner gas hob
 - Twin cavity oven, 8/5 functions
 - Stainless steel
- More details on p24



RV961

- All-electric
 - 5 zone ceramic hob
 - Twin cavity oven, 8/5 functions
 - Stainless steel
- More details on p25

100cm wide



RV1002

- Dual fuel
 - 6 burner gas hob
 - Twin cavity oven, 8/5 functions
 - Stainless steel
- More details on p26

120cm wide



RV1200

- Dual fuel
 - 5 burner gas hob and ceramic griddle
 - Triple cavity ovens, 8/4/4 functions
 - Stainless steel
- More details on p27



Cream

Black

RVC931

90cm traditional triple cavity range cooker, electric ovens, gas hob

Main oven



Second oven



Third oven



Hob features

- 5 burners
- Wok burner
- Automatic ignition
- Cast iron pan supports
- Rear back guard
- Flame failure safety device included

Oven features

- Easy clean enamel interior
- Cooling fan
- Interior halogen lights
- Chromed rack sides with integrated anti-tilt shelves
- Push button programmable electronic clock/timer
- Removable doors
- Main oven:
 - Double glazed door with removable inner door glass for easy cleaning

Other features

- Adjustable feet

Accessories

- Cast iron wok support
- 4 flat shelves
- 2 grill pans with grid
- 2 grill pan handles
- Plate warmer rack/shelf for second oven
- LPG conversion kit included
- Main oven - Catalytic liners
- Third oven - Telescopic shelf kit

Optional accessories

- Griddle, RG1-E
- Telescopic shelf kit, TSK4
- Catalytic liners (for main oven only), C5OL
- Catalytic liners (for third oven only), C6OL
- Pizza stone, ACG10
- Glass oven tray, ACG20

Available in

- Cream
- Black

Hob specification

- Front left, rapid: 3kW
- Front right, auxiliary: 1kW
- Centre, triple-ring/wok: 4kW
- Rear left, semi-rapid: 1.75kW
- Rear right, semi-rapid: 1.75kW

Technical specification

- Main oven useable capacity: 59L net
- Second oven useable capacity: 73L net
- Third oven useable capacity: 37L net
- Rated gas input: 11.5kW
- Rated electrical power: 7.3kW
- Power supply required: 32A

Energy efficiency rating

- Energy rating (main oven): A
- Energy rating (second oven): B

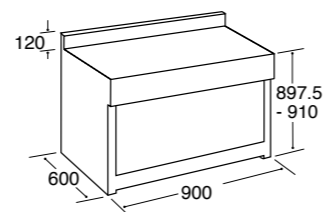

RV911

90cm single cavity range cooker, electric oven, gas hob

Main oven



Hob features

- 5 burners
- Wok burner
- Automatic ignition
- Cast iron pan supports
- Flame failure safety device included

Oven features

- Easy clean enamel interior
- Cooling fan
- Interior halogen lights
- Chromed rack sides with integrated anti-tilt shelves
- Touch control programmable electronic clock/timer
- Triple glazed door with removable inner door glass for easy cleaning
- Removable doors

Other features

- Adjustable feet
- Storage compartment

Accessories

- Cast iron wok support
- 2 flat shelves
- 1 grill pan with grid
- LPG conversion kit included

Optional accessories

- Griddle, RG1-E
- Pizza stone, ACG10
- Glass oven tray, ACG20

Available in

- Stainless steel

Hob specification

- Front left, rapid: 3kW
- Front right, rapid: 3kW
- Centre, wok: 3.7kW
- Rear left, semi-rapid: 1.75kW
- Rear right, semi-rapid: 1.75kW

Technical specification

- Main oven useable capacity: 103L net
- Rated gas input: 13.2kW
- Rated electrical power: 3.38kW
- Power supply required: 16A

Energy efficiency rating

- Energy rating: A

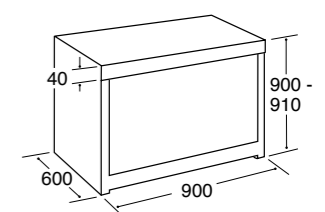



RV921
90cm twin cavity range cooker, electric ovens, gas hob

Main oven



Second oven



Hob features

- 5 burners
- Wok burner
- Automatic ignition
- Cast iron pan supports
- Flame failure safety device included

Oven features

- Easy clean enamel interior
- Cooling fan
- Interior halogen lights
- Chromed rack sides with integrated anti-tilt shelves
- Touch control programmable electronic clock/timer
- Triple glazed doors with removable inner door glass for easy cleaning
- Removable doors

Other features

- Adjustable feet
- Storage compartment

Accessories

- Cast iron wok support
- 2 + 2 flat shelves
- 2 grill pans with grids
- LPG conversion kit included

Optional accessories

- Griddle, RG1-E
- Pizza stone, ACG10
- Glass oven tray, ACG20

Available in

- Stainless steel

Hob specification

- Front left, rapid: 3kW
- Front right, rapid: 3kW
- Centre, wok: 3.7kW
- Rear left, semi-rapid: 1.75kW
- Rear right, semi-rapid: 1.75kW

Technical specification

- Main oven useable capacity: 63L net
- Second oven useable capacity: 32L net
- Rated gas input: 13.2kW
- Rated electrical power: 4.35kW
- Power supply required: 20A

Energy efficiency rating

- Energy rating (main oven): A
- Energy rating (second oven): B

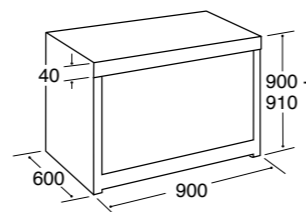

RV961
90cm twin cavity range cooker, electric ovens, ceramic hob

Main oven



Second oven



Hob features

- 5 zones including 2 dual zones
- Residual heat indicators

Oven features

- Easy clean enamel interior
- Cooling fan
- Interior halogen lights
- Chromed rack sides with integrated anti-tilt shelves
- Touch control programmable electronic clock/timer
- Triple glazed door with removable inner door glass for easy cleaning
- Removable doors

Other features

- Adjustable feet
- Storage compartment

Accessories

- 2 + 2 flat shelves

- 2 grill pans with grids

Optional accessories

- Pizza stone, ACG10
- Glass oven tray, ACG20

Available in

- Stainless steel

Hob specification

- Front left:
 - 140mm: 1.1kW
 - 210mm: 2kW
- Front right, 140mm: 1.2kW
- Rear left, 140mm: 1.2kW
- Rear right, 180mm: 1.8kW
- Centre, dual:
 - 140mm: 1.1kW
 - 250mm: 2kW

Technical specification

- Main oven useable capacity: 63L net
- Second oven useable capacity: 32L net

- Rated electrical power: 12.78kW
- Power supply required: 45A

Energy efficiency rating

- Energy rating (main oven): A
- Energy rating (second oven): B

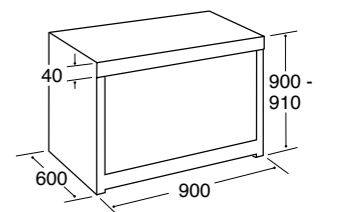



RV1002
100cm twin cavity range cooker, electric ovens, gas hobs

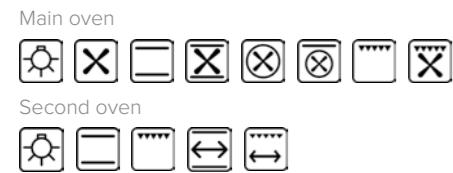

- Hob features**
- 6 burners
 - Wok burner
 - Automatic ignition
 - Cast iron pan supports
 - Rear back guard
 - Flame failure safety device included

- Oven features**
- Easy clean enamel interior
 - Cooling fan
 - Interior halogen lights
 - Chromed rack sides with integrated anti-tilt shelves
 - Touch control programmable electronic clock/timer
 - Double glazed door with removable inner door glass for easy cleaning
 - Removable doors

- Other features**
- Adjustable feet
 - Storage drawer

- Accessories**
- Cast iron wok support
 - 2 space saver shelves
 - 2 grill pans with grids
 - 2 grill pan handles
 - 1 rotisserie kit
 - Plate warmer rack/shelf for second oven
 - LPG conversion kit included
 - Griddle, RG1-E

- Optional accessories**
- Catalytic liners (for main oven only), C3OL
 - Pizza stone, ACG10
 - Glass oven tray, ACG20

- Available in**
- Stainless steel

- Hob specification**
- Front left, triple-ring/wok: 3.5kW
 - Front centre, auxiliary: 1kW
 - Front right, triple-ring/wok: 3.5kW
 - Rear left, semi-rapid: 1.75kW
 - Rear centre, rapid: 3kW
 - Rear right, semi-rapid: 1.75kW

- Technical specification**
- Main oven useable capacity: 70L net
 - Second oven useable capacity: 45L net
 - Rated gas input: 14.5kW
 - Rated electrical power: 3.79kW
 - Power supply required: 20A

- Energy efficiency rating**
- Energy rating (main oven): B
 - Energy rating (second oven): B

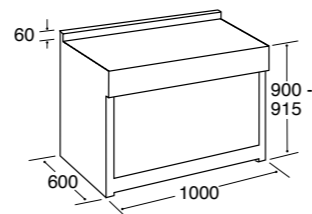

RV1200
120cm triple cavity range cooker, electric ovens, gas hob and ceramic griddle



- Hob features**
- 5 gas burners and 1 ceramic griddle zone
 - 12 power levels on griddle zone
 - Wok burner
 - Automatic ignition
 - Cast iron pan supports
 - Rear back guard
 - Flame failure safety device included

- Oven features**
- Easy clean enamel interior
 - Cooling fan
 - Interior halogen lights
 - Chromed rack sides with integrated anti-tilt shelves
 - Touch control programmable electronic clock/timer
 - Double glazed door with removable inner door glass for easy cleaning
 - Removable doors

- Other features**
- Adjustable feet
 - Storage drawer

- Accessories**
- Cast iron wok support
 - 2 flat shelves
 - 2 space saver shelves
 - 2 grill pans with grid
 - 2 grill pan handles
 - 1 aluminium pastry plate
 - LPG conversion kit included

- Optional accessories**
- Griddle, RG1-E
 - Catalytic liners (main and second ovens), C5OL
 - Catalytic liners (third oven), C6OL
 - Pizza stone, ACG10
 - Glass oven tray, ACG20

- Available in**
- Stainless steel

- Hob specification**
- Front left, triple-ring/wok: 3.5kW
 - Front right, triple-ring/wok: 3.5kW
 - Centre left gas, dual: 4.5kW
 - Centre right, ceramic griddle: 1.3kW
 - Rear left, semi-rapid: 1.75kW
 - Rear right, semi-rapid: 1.75kW

- Technical specification**
- Main oven useable capacity: 59L net
 - Second oven useable capacity: 59L net
 - Third oven useable capacity: 37L net
 - Rated gas input: 15kW
 - Rated electrical power: 7.9kW
 - Power supply required: 32A

- Energy efficiency rating**
- Energy rating (main oven): A
 - Energy rating (second oven): A
 - Energy rating (third oven): A

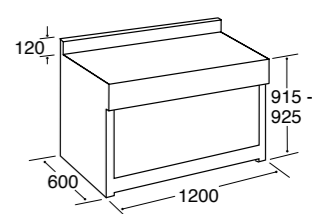

Single ovens

Our expertise in appliance manufacture means that whichever of our many stylish models you choose, you can be certain of high performance, advanced technology and, of course, reliability.



We understand that your oven needs to do more than just cook food well. That's why we've combined stunning new designs with the best cooking performance possible. With our wide range of ovens, including pyrolytic, touch control and gas models, you are guaranteed to find the perfect oven for your home.

Single ovens



Large capacity ovens

CDA's range of single ovens, SK110, SK210, SK310, SK410 and SK511 features an extra-large cavity with a gross capacity of 80L. In real terms, this extra usable cooking space, plus additional shelf positions, will allow you to achieve better cooking results with more food in the oven at the same time.

The range features an energy rating of A and built in safety features, such as anti-tilt shelving to reduce accidents removing hot food from the oven, as standard.

With extra shelf positions available on the SK110, SK210, SK310, SK410 and SK511 oven models, up to 6 trays of cookies may be baked at once. This extra space means that you will also have no problem roasting a joint of meat, potatoes and vegetables together for a special family meal.

Stylish aesthetics

Our range of single ovens offers considered design features that will complete your kitchen perfectly. From ergonomically designed control knobs to brushed steel finish door handles and side strips, whichever model you choose, you can be sure that every detail has been deliberated to bring you the best in function and style.



Extra large cavity

Cutting edge style, performance and reliability



Easy clean enamel interior

Our ovens have a smooth, easy clean enamel interior. By using the highest grade of enamel during production, the oven walls are less porous and therefore much less susceptible to absorbing grease and residue from food whilst cooking; this results in an easy to maintain oven with effortless cleaning.



Self-cleaning

Spend less time on chores by choosing the SK511 pyrolytic oven. The self-cleaning programme on the SK511 oven will allow you to get on with other things whilst your oven 'cleans itself'. The programme works by automatically locking the door, for your family's safety, and heating the internal oven cavity to over 450°C to incinerate residual cooking fat or spills to a fine ash. All you need to do is simply wipe away the small amount of ash from the bottom of your oven after the cycle has finished. What's more, running a pyrolytic programme costs around 45p; much cheaper than branded oven cleaners.

Offset lateral halogen lights



Offset lateral halogen lights

The halogen lighting inside the SK310 and SK410 models provides clear illumination whilst cooking, allowing you to easily check the progress of your meal. By removing the need to open the oven door during cooking, an even temperature can be maintained to produce perfect results every time.

Cool door with removable glass

The SG120, SK110 and SK210 come with double glazed doors with removable inner glass for easy cleaning. The SC620, SK310 and SK410 are fitted with triple glazed doors and the SK511 pyrolytic oven is quadruple glazed. This enables the door to remain cool to the touch when cooking at high temperatures.



Our touch control models, the SK410, SK511, VC801, VK702 and VK902, have discrete icons that are illuminated and clearly visible when in use but barely noticeable when not, leaving an uninterrupted clean line across your integrated CDA appliances.

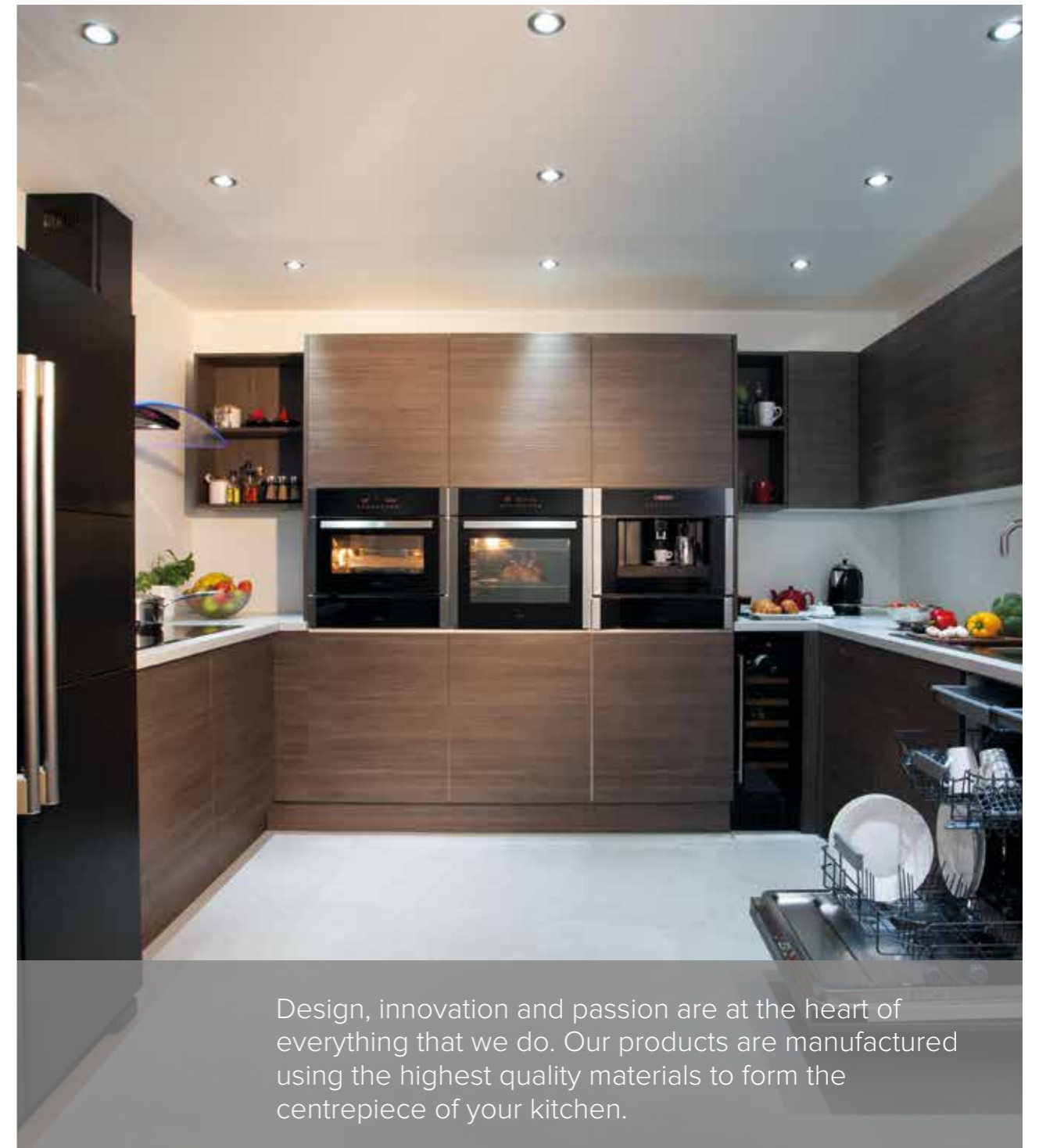

Design, innovation and passion are at the heart of everything that we do. Our products are manufactured using the highest quality materials to form the centrepiece of your kitchen.

Quick guide to single ovens

CDA offer a choice of designs and features to meet a broad range of tastes.

Products with this icon have a huge 76L net capacity providing plenty of room to cook for the whole family.



SG120

- 5 function gas oven
 - Capacity: 56L net
 - Available in stainless steel or white
- More details on p34



SC620

- 7 functions
 - Reversible side opening
 - Capacity: 59L net
- More details on p34



SK410

- 10 functions
 - Full touch control
 - Capacity: 76L net
- More details on p36



SK511

- 11 functions
 - Full touch control
 - Pyrolytic
 - Capacity: 76L net
 - Available in stainless steel or black
- More details on p38



SK110

- 4 functions
 - Capacity: 76L net
- More details on p35



SK210

- 4 functions
 - Capacity: 76L net
- More details on p35



SK310

- 7 functions
 - Capacity: 76L net
 - Available in stainless steel or black
- More details on p36



SK381

- 8 functions
 - 90cm extra wide capacity
 - Capacity: 87L net
- More details on p39



The SG120
 The SG120 incorporates an indirect burner in conjunction with a circular fan for improved circulation.



SG120
 Five function gas oven

SC620
 Seven function electric side opening oven

SK110
 Four function electric fan oven

SK210
 Four function electric fan oven



- Features**
- 60 minute minder
 - Easy clean enamel interior
 - Interior light
 - Cooling fan
 - Chromed rack sides with integrated anti-tilt shelves
 - Double glazed removable door with removable inner glass for easy cleaning
 - Flame failure safety device included

- Total useable capacity: 56L net

Accessories

- 2 flat oven shelves
- 1 grill pan with grid
- LPG conversion kit included

Optional accessories

- Pizza stone, ACG10
- Glass oven tray, ACG20

Available in

- Stainless steel
- White

Technical specification

- Rated gas input: 2.7kW
- Rated electrical power: 60W
- Power supply required: 3A

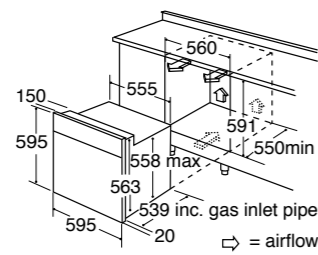

- Features**
- Touch control programmable clock/timer
 - Easy clean enamel interior
 - Interior halogen light
 - Cooling fan
 - Chromed rack sides with integrated anti-tilt shelves
 - Triple glazed removable cool door with removable inner glass for easy cleaning
 - Reversible side opening door

- Total useable capacity: 59L net

Accessories

- 2 flat oven shelves
- 1 grill pan with grid

Optional accessories

- Pizza stone, ACG10
- Glass oven tray, ACG20

Available in

- Stainless steel

Technical specification

- Rated electrical power: 2kW
- Power supply required: 13A

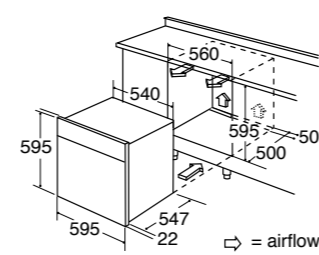

- Features**
- Easy clean enamel interior
 - Interior halogen light
 - Cooling fan
 - Chromed rack sides with integrated anti-tilt shelves
 - Double glazed removable door with removable inner glass for easy cleaning
 - 6 shelf positions

Accessories

- 2 flat oven shelves
- 1 grill pan with grid

Optional accessories

- Telescopic shelf kit, TSK3
- Pizza stone, ACG10
- Glass oven tray, ACG20

Available in

- Stainless steel

Technical specification

- Rated electrical power: 2.16kW
- Power supply required: 13A
- Total useable capacity: 76L net

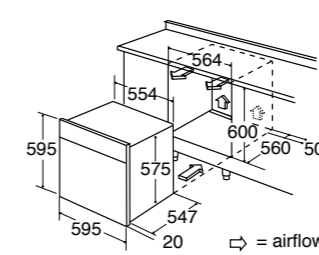

- Features**
- Touch control programmable clock/timer
 - Easy clean enamel interior
 - Interior halogen light
 - Cooling fan
 - Chromed rack sides with integrated anti-tilt shelves
 - Double glazed removable door with removable inner glass for easy cleaning
 - 6 shelf positions

Accessories

- 2 flat oven shelves
- 1 grill pan with grid

Optional accessories

- Telescopic shelf kit, TSK3
- Pizza stone, ACG10
- Glass oven tray, ACG20

Available in

- Stainless steel

Technical specification

- Rated electrical power: 2.16kW
- Power supply required: 13A
- Total useable capacity: 76L net

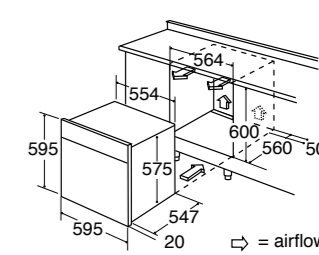



Stainless steel



Black

SK310
Seven function electric oven



- Features**
- Touch control programmable clock/timer
 - Easy clean enamel interior
 - Offset lateral halogen lights
 - Cooling fan
 - Chromed rack sides with integrated anti-tilt shelves
 - Triple glazed removable cool door with removable inner glass for easy cleaning
 - 6 shelf positions

- Accessories**
- 2 flat oven shelves
 - 1 grill pan with grid

- Optional accessories**
- Telescopic shelf kit, TSK3
 - Pizza stone, ACG10
 - Glass oven tray, ACG20

- Available in**
- Stainless steel
 - Black

- Technical specification**
- Rated electrical power: 2.16kW

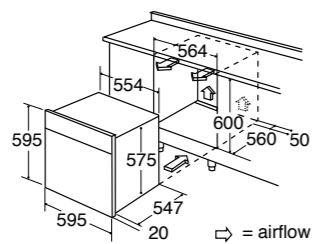

SK410
Ten function electric LCD oven



- Features**
- Full touch control
 - LCD display
 - Easy clean enamel interior
 - Offset lateral halogen lights
 - Cooling fan
 - Chromed rack sides with integrated anti-tilt shelves
 - Triple glazed removable cool door with removable inner glass for easy cleaning
 - 6 shelf positions
 - Booster function for rapid preheat
 - Safety key lock
 - Memory function

- Accessories**
- 2 flat oven shelves
 - 1 grill pan with grid

- Optional accessories**
- Telescopic shelf kit, TSK3
 - Pizza stone, ACG10
 - Glass oven tray, ACG20

- Available in**
- Stainless steel

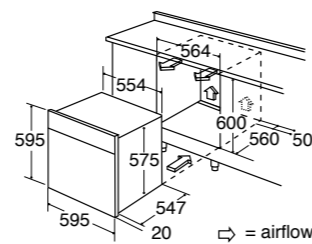



Stainless steel Black

SK511
Eleven function LCD pyrolytic oven



- Features
- Full touch control
 - LCD display
 - Easy clean enamel interior
 - Interior halogen light
 - Cooling fan
 - Chromed rack sides with integrated anti-tilt shelves
 - Quadruple glazed removable cool door with removable inner glass for easy cleaning
 - 6 shelf positions
 - Booster function for rapid preheat
 - Safety key lock
 - Memory function

- Accessories
- 2 flat oven shelves
 - 1 grill pan with grid

- Optional accessories
- Telescopic shelf kit, TSK3
 - Pizza stone, ACG10
 - Glass oven tray, ACG20

- Available in
- Stainless steel
 - Black

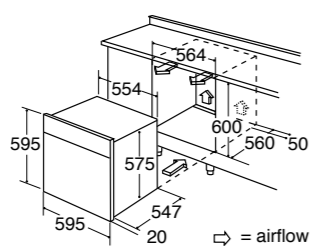

This 90cm wide oven provides a huge internal net capacity of 87L - ideal for entertaining or large families. Three chickens can cook side by side on one shelf.



SK381
90cm eight function electric oven

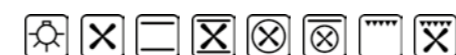

- Features
- Touch control
 - programmable clock/timer
 - Easy clean enamel interior
 - Twin interior halogen lights
 - Cooling fan
 - Chromed rack sides with integrated anti-tilt shelves
 - Double glazed removable door with removable inner glass for easy cleaning
 - Extra large cavity

- Accessories
- 1 flat oven shelf
 - 1 space saver oven shelf
 - 1 grill pan with grid
 - 2 grill pan handles

- Optional accessories
- Catalytic liners (3 piece), C9OL
 - Pizza stone, ACG10
 - Glass oven tray, ACG20

- Available in
- Stainless steel

- Technical specification
- Rated electrical power: 3.05kW

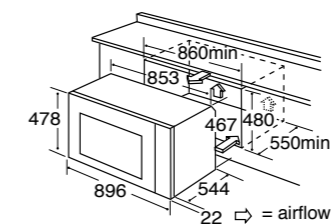

Compacts

A range of useful and innovative appliances to add functionality and that special finishing touch to your kitchen.

Build your personalised cooking space by combining any of our compact appliances. Choose from steam and grill, combination microwave and grill, fan oven or warming drawers to suit your needs.



Steam cooking

Now with full touch control, the VK702SS offers healthy, vitamin preserving cooking at home. The refillable reservoir means that there is no need to connect to the mains water supply and the combination grill allows you to brown food for an appetising finish.



Compact ovens

Our compact range offers a steam oven and a compact combination model. The VK902 provides a grill, microwave and a fan oven all in one neat space, making it the perfect choice for kitchens where space is limited.



Drawers

A warming drawer is ideal for warming plates, dough proving, melting chocolate, making yoghurt or keeping dishes and cooked food warm. These are so useful that once you've had one you'll never want to do without!

Choose between a 'push-push' open and close action, where you press the drawer surface to make it slide open and again to close it, or a traditional ergonomic handle design to finish your kitchen.



Compact coffee maker

The VC801 automatic coffee maker will make mornings worth waking up for. This built-in 60cm coffee maker brings CDA's sleek styling into your kitchen design whilst offering superb features and functions. It comes with full touch control, multiple grind settings along with adjustable coffee strength and quantity for your perfect hot drink. You can use coffee beans or pre-ground coffee with this machine making it truly flexible to your lifestyle.

Quick guide to compact cooking and microwaves

These versatile compact appliances look stunning when installed together as a bank. Install warming drawers beneath for ultimate cooking flexibility.

We have a choice of microwaves to suit your requirements - freestanding or built-in options are available.

Compact refrigeration

Please see our refrigeration section for the following compact refrigeration products:



FWV452

- Built-in compact wine cooler - See page 142.



BVB4

- Built-in draught beer dispenser - See page 144.

Microwaves



VM100

- Freestanding microwave oven
 - LED timer and clock
 - Quick start
- More details on p44



VM200

- Freestanding microwave oven and grill
 - LED timer and clock
 - Quick start
- More details on p44

Microwaves



VM130

- Built-in microwave oven
 - LED timer and clock
 - Quick start
 - Available in stainless steel or black
- More details on p45



VM230

- Built-in microwave oven and grill
 - LED timer and clock
 - Quick start
 - Available in stainless steel or black
- More details on p45

Compact appliances



VK702

- Compact steam oven and grill
 - Full touch control
 - LED display
- More details on p47



VK902

- Compact combination microwave, grill and fan oven
 - Full touch control
 - LED display
- More details on p47

Drawers



VW142

- Warming drawer
 - 6 place settings
 - Variable temperature
 - Smooth runners
- More details on p50



VW152

- Push-push warming drawer
 - 6 place settings
 - Variable temperature
 - Smooth runners
- More details on p50

Microwaves



VM451

- Built-in microwave oven, grill and convection oven
 - LED timer and clock
 - Auto defrost
 - Quick start
- More details on p46



VM550

- Wall unit microwave oven
 - LED timer and clock
 - Auto defrost
 - Quick start
- More details on p46

Compact appliances



VC801

- Compact coffee maker
 - 3 coffee strength settings
 - Touch control
- More details on p48

Drawers



VW281

- Large warming drawer
 - 12 place settings
 - Variable temperature
 - Smooth runners
 - Non-slip silicone mat
- More details on p51

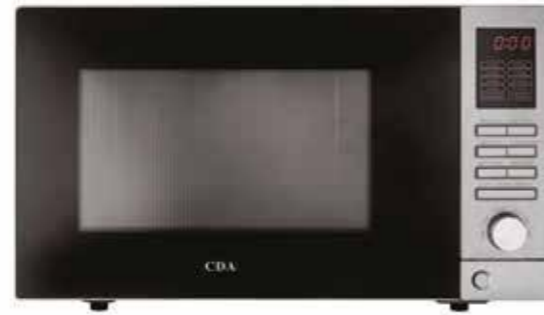

VM100
Freestanding microwave oven

- Features**
- Microwave function
 - Auto defrost
 - Quick start
 - LED timer and clock
 - 5 microwave power levels - 900W max
 - Interior lateral light
 - Acoustic end of programme signal
 - Left hand hinged door
 - Safety key lock

- Accessories**
- Glass turntable - 315mm diameter
 - Turntable ring

- Available in**
- Stainless steel

- Technical specification**
- Total useable capacity: 25L net
 - Rated electrical power: 1.45kW
 - Power supply required: 13A

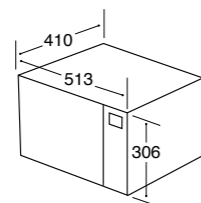

VM200
Freestanding microwave oven and grill

- Features**
- Microwave function
 - Grill function
 - Microwave/grill function
 - Auto defrost
 - Quick start
 - LED timer and clock
 - 5 microwave power levels - 900W max
 - Grill rating - 1kW
 - Interior lateral light
 - Acoustic end of programme signal
 - Left hand hinged door
 - Safety key lock

- Accessories**
- Glass turntable - 315mm diameter
 - Turntable ring
 - Trivet

- Available in**
- Stainless steel

- Technical specification**
- Total useable capacity: 25L net
 - Rated electrical power: 1.45kW
 - Power supply required: 13A

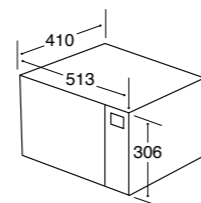

VM130
Built-in microwave oven

- Features**
- Microwave function
 - Auto defrost
 - Quick start
 - LED timer and clock
 - 5 microwave power levels - 900W max
 - Interior lateral light
 - Acoustic end of programme signal
 - Left hand hinged door
 - Safety key lock

- Accessories**
- Glass turntable - 315mm diameter
 - Turntable ring

- Available in**
- Stainless steel
 - Black

- Technical specification**
- Total useable capacity: 25L net
 - Rated electrical power: 1.45kW
 - Power supply required: 13A

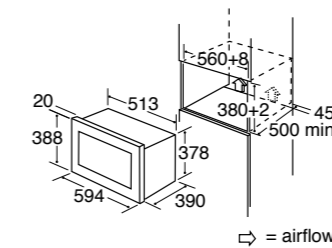

VM230
Built-in microwave oven and grill

- Features**
- Microwave function
 - Grill function
 - Microwave/grill function
 - Auto defrost
 - Quick start
 - LED timer and clock
 - 5 microwave power levels - 900W max
 - Grill rating - 1kW
 - Interior lateral light
 - Acoustic end of programme signal
 - Left hand hinged door
 - Safety key lock

- Accessories**
- Glass turntable - 315mm diameter
 - Turntable ring
 - Trivet

- Available in**
- Stainless steel
 - Black

- Technical specification**
- Total useable capacity: 25L net
 - Rated electrical power: 1.45kW
 - Power supply required: 13A

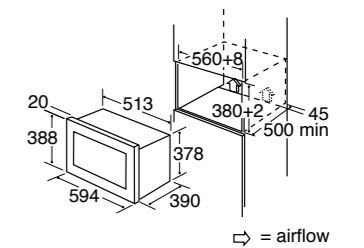



VM451
Built-in microwave oven, grill and convection oven

- Features**
- Microwave function
 - Grill function
 - Convection oven function
 - Microwave/grill function
 - Microwave/convection oven function
 - Grill/convection function
 - Combination cooking function
 - Auto defrost
 - 10 auto cook programmes
 - Quick start
 - LED timer and clock
 - 5 microwave power levels - 900W max
 - Grill rating 1.1kW
 - Convection oven rating - 2.5kW (maximum temperature on convection programme is 220_C)
 - Interior lateral light
 - Acoustic end of programme signal
 - Left hand hinged door
 - Safety key lock

- Technical specification**
- Total useable capacity: 25L net
 - Rated electrical power: 2.5kW
 - Power supply required: 13A
- Fitting note**
- This microwave oven has a convection oven function but is not intended to be used as a substitute for a standard oven.
 - Not suitable for built-under worktop fitting.

- Accessories**
- Glass turntable - 315mm diameter
 - Turntable ring
 - Trivet

- Available in**
- Stainless steel

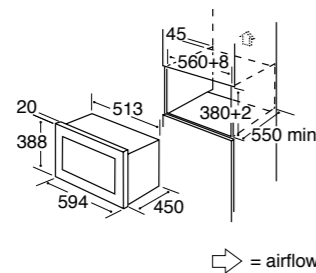

VM550
Wall unit microwave oven

- Features**
- Microwave function
 - Manual defrost
 - Auto defrost
 - 8 auto-cook programmes
 - Quick start
 - LED timer and clock
 - 5 microwave power levels - 700W max
 - Interior light
 - Acoustic end of programme signal
 - Left hand hinged door
 - Safety key lock

- Accessories**
- Glass turntable - 245mm diameter
 - Turntable ring

- Available in**
- Stainless steel

- Technical specification**
- Total useable capacity: 17L net
 - Rated electrical power: 1.05kW
 - Power supply required: 5A

- Fitting note**
- Not suitable for built-under worktop fitting.

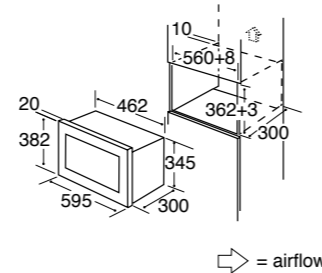

Did you know?
The steam function, used on a low temperature setting, is perfect for gentle defrosting.



VK702
Compact steam oven and grill



- Features**
- Full touch control
 - LED display
 - Interior lateral halogen light
 - Stainless steel interior
 - Variable temperature
 - Variable grill
 - Removable 1L water reservoir
 - 8 auto-cook programmes
 - Programmable clock/timer
 - Double glazed removable door with removable inner door glass for easy cleaning
 - Safety key lock

- Fitting note**
- Should be installed as a built-in appliance.

- Accessories**
- Stainless steel steam cooking set
 - Trivet
 - Wire shelf

- Available in**
- Stainless steel

- Technical specification**
- Total useable capacity: 32L net
 - Rated electrical power: 1.3kW
 - Power supply required: 13A

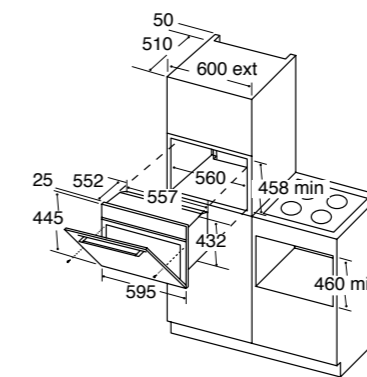

VK902
Compact combination microwave, grill and fan oven



- Features**
- Full touch control
 - LED display
 - 6 microwave power levels - 900W max
 - Interior light
 - Auto defrost
 - Programmable clock/timer
 - Cooling fan
 - Double glazed removable door
 - Safety key lock
 - Acoustic end of programme signal

- Fitting note**
- Should be installed as a built-in appliance.

- Accessories**
- Wire shelf
 - Glass turntable - 360mm diameter
 - Turntable ring
 - Trivet and grill pan

- Available in**
- Stainless steel

- Technical specification**
- Total useable capacity: 40L net
 - Rated electrical power: 3.1kW
 - Power supply required: 13A

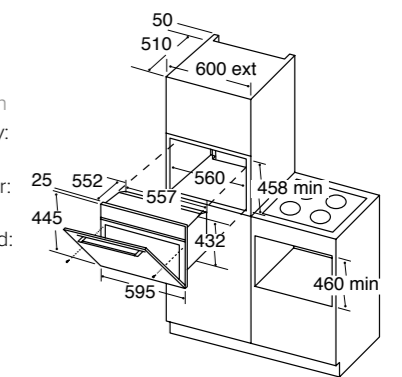



VC801
Fully automatic coffee maker

Features

- Fully automatic
- Full touch control
- Electronic programmer with LCD display
- 3 coffee strength settings
- Steam nozzle
- One or two cups
- Compatible with ground coffee and coffee beans
- Hot water and steam
- Integral water tank: 1.8L
- Integral coffee container: 0.2kg
- Low coffee warning
- Low water warning
- Removable drip tray
- Adjustable grind setting
- Integrated coffee grinder



- Available in
- Stainless steel

- Technical specification
- Rated electrical power: 1.35kW
 - Power supply required: 13A
 - Pump pressure: 15Bar

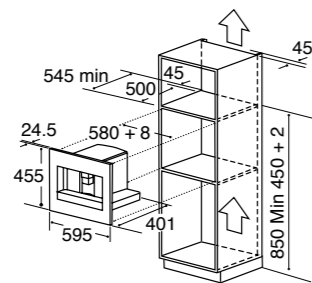

⇨ = airflow



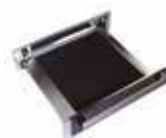

VW142
Warming drawer

Features

- Fan heat
- Temperature adjustable from 40°C to 80°C
- 6 place settings
- Smooth runners
- Power indicator light

Available in

- Stainless steel

Technical specification

- Rated electrical power: 440W max
- Power supply required: 3A
- Maximum capacity: 20kg

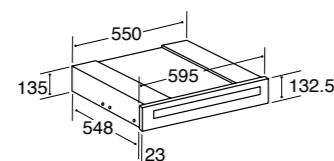

VW152
Push-push warming drawer

Features

- Fan heat
- Temperature adjustable from 40°C to 80°C
- 6 place settings
- Smooth runners
- Power indicator light
- Push-push opening

Available in

- Stainless steel

Technical specification

- Rated electrical power: 440W max
- Power supply required: 3A
- Maximum capacity: 20kg

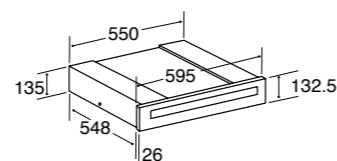

VW281
Large warming drawer

Features

- Fan heat
- Temperature adjustable from 30°C to 80°C
- 12 place settings
- Smooth runners
- Non-slip silicone mat
- Power indicator light

Available in

- Stainless steel

Technical specification

- Rated electrical power: 432W max
- Power supply required: 3A
- Maximum capacity: 25kg

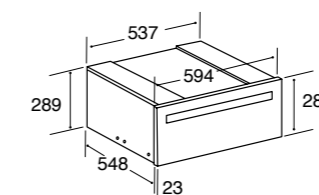



Double ovens

Available in both built-in and built-under options, CDA A rated double ovens offer a winning combination of extra cooking space and outstanding features.

Programmable timers on all double oven models allow you to automate cooking times, leaving you to get on with everything else.

Double ovens

DC740 and DC940 double ovens

Choose between the DC740 & DC940 for useful extra cooking space at either an under counter 'built-under' or eye level 'built-in' height and design your cooking space around you.



DK751, DK951 and DK1151 double ovens

The DK751, DK951 & DK1151 models sharpen up the styling with black glass that is opaque until the internal light is switched on, providing uninterrupted clean lines throughout your kitchen when you are not cooking. With multi-function main ovens on these models you will have more flexibility in cooking style at your fingertips.



DK1151 double tower oven

Our double tower oven, the DK1151 offers the flexibility of two full size single oven cavities combined into one appliance. What's more, each oven may be individually controlled and comes with full multi-function cooking options.



Quick guide to double ovens

The CDA range of double ovens includes both built-in and built-under models to suit your kitchen.

All double ovens are A rated in both oven cavities.



DC740

- Built-under
 - 4/3 functions
 - Touch control programmer
 - Available in stainless steel, white and black
- More details on p56



DC940

- Built-in
 - 4/3 functions
 - Touch control programmer
 - Available in stainless steel, white and black
- More details on p57

Choose from either a built-in double oven, to install and cook at eye level, or a built-under model that fits beneath your worktop making the most of low level space.



DK751

- Built-under
 - 3/8 functions
 - Touch control programmer
- More details on p58



DK951

- Built-in
 - 3/8 functions
 - Touch control programmer
- More details on p59



DK1151

- Built-in tower oven
 - 8/8 functions
 - Touch control programmer
- More details on p60



DC740
Built-under electric double oven

Top oven



Main oven



- Features**
- Touch control programmable electronic clock/timer
 - Easy clean enamel interior
 - Interior halogen lights
 - Cooling fan
 - Chromed rack sides with integrated anti-tilt shelves
 - Double glazed removable doors with removable inner glass for easy cleaning

Accessories

- Grill pan with grid
- 3 flat oven shelves

Optional accessories

- Pizza stone, ACG10
- Glass oven tray, ACG20

- Available in**
- Stainless steel
 - Black
 - White

Technical specification

- Top oven useable capacity: 34L net
- Main oven useable capacity: 50L net
- Rated electrical power: 4.3kW
- Power supply required: 20A

Fitting note

- Please ensure you check that there is sufficient clearance above built-under ovens when fitting the relevant hob.

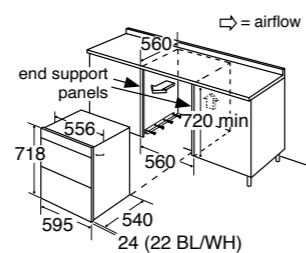

DC940
Built-in electric double oven

Top oven



Main oven



- Features**
- Touch control programmable electronic clock/timer
 - Easy clean enamel interior
 - Interior halogen lights
 - Cooling fan
 - Chromed rack sides with integrated anti-tilt shelves
 - Double glazed removable doors with removable inner glass for easy cleaning

Accessories

- Grill pan with grid
- 3 flat oven shelves

Optional accessories

- Pizza stone, ACG10
- Glass oven tray, ACG20

- Available in**
- Stainless steel
 - Black
 - White

Technical specification

- Top oven useable capacity: 34L net
- Main oven useable capacity: 59L net
- Rated electrical power: 4.3kW
- Power supply required: 20A

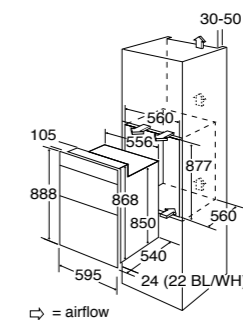



DK751
Built-under electric double oven

Top oven



Main oven



- Features**
- Touch control programmable electronic clock/timer
 - Easy clean enamel interior
 - Interior halogen lights
 - Cooling fan
 - Chromed rack sides with integrated anti-tilt shelves
 - Double glazed removable doors with removable inner glass for easy cleaning

Accessories

- 2 flat oven shelves
- 1 space saver oven shelf
- 1 grill pan with grid
- 2 grill pan handles

Optional accessories

- Catalytic liners (top oven only), C6OL

- Catalytic liners (main oven only), C7OL
- Pizza stone, ACG10
- Glass oven tray, ACG20

Available in

- Stainless steel

Technical specification

- Top oven useable capacity: 37L net
- Main oven useable capacity: 50L net
- Rated electrical power: 4.08kW
- Power supply required: 20A

Fitting note

- Please ensure you check that there is sufficient clearance above built-under ovens when fitting the relevant hob.

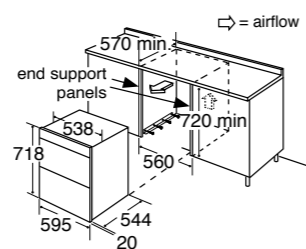

DK951
Built-in electric double oven

Top oven



Main oven



- Features**
- Touch control programmable electronic clock/timer
 - Easy clean enamel interior
 - Interior halogen lights
 - Cooling fan
 - Chromed rack sides with integrated anti-tilt shelves
 - Double glazed removable doors with removable inner glass for easy cleaning

Accessories

- 2 flat oven shelves
- 1 space saver oven shelf
- 1 grill pan with grid
- 2 grill pan handles

Optional accessories

- Catalytic liners (top oven only), C6OL

- Catalytic liners (main oven only), C10OL
- Pizza stone, ACG10
- Glass oven tray, ACG20

Available in

- Stainless steel

Technical specification

- Top oven useable capacity: 37L net
- Main oven useable capacity: 59L net
- Rated electrical power: 4.4kW
- Power supply required: 20A

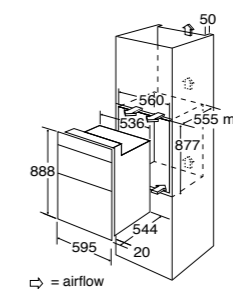



This double tower oven has the capacity of two full size ovens, providing plenty of cooking space.

DK1151
Built-in electric double tower oven

Top oven



Main oven



- Features**
- Touch control programmable electronic clock/timer
 - Easy clean enamel interior
 - Interior lateral halogen lights
 - Cooling fan
 - Chromed rack sides with integrated anti-tilt shelves
 - Double glazed removable doors with removable inner door glass for easy cleaning

- Accessories**
- 2 flat oven shelves
 - 2 space saver oven shelves
 - 2 grill pans with grids
 - 2 grill pan handles

- Optional accessories**
- Catalytic liners (2 required), C100L
 - Pizza stone, ACG10
 - Glass oven tray, ACG20

- Available in**
- Stainless steel

- Technical specification**
- Top oven useable capacity: 59L net
 - Bottom oven useable capacity: 59L net
 - Rated electrical power: 4.77kW
 - Power supply required: 25A

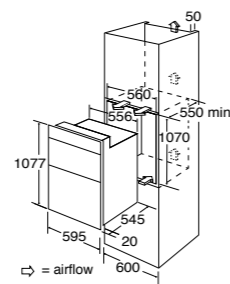

Hobs

Everyone has their preference and we offer everything from bridging induction hobs to professional style gas hobs in sizes from domino to extra wide.



Look out for our bridging induction hobs which allow you to turn two zones into one large induction surface, maximising your cooking space.

Gas hobs

From a practical four burner model in stainless steel, to a huge six burner design we have every configuration possible to ensure that our gas hob range works for you, whatever your cooking style. We have included wok burners for maximum power when you need it and additional wok supports to allow you to get creative with your cooking.

Choose between cast iron pan supports for a solid and professional feel or our dishwasher enamel versions for practicality and easy maintenance.



Ceramic hobs

Our ceramic hob range is a practical option for those wanting an easy to clean cooking area. The resistant glass-ceramic material is ideal for households where a quick wipe over after cooking is all you have time for.

Choose from either touch control or rotary control knobs to suit your preference. We have even included both side and front control options to allow you to choose the exact layout that works best for you.

Some of our larger ceramic models include built in dual cooking zones that allow you to increase the size of the heating zone. This is brilliant for being economical and efficient when you are using smaller pans and powerful enough for your large cookware, just when you need it.

Some CDA hobs feature Schott Ceran® glass, an extremely stable material that is resistant against abrupt temperature changes. It is also designed to withstand daily wear and tear that can occur in the kitchen whilst cooking. The four millimetre thick glass is extremely heat-permeable. The glass is able to transfer heat quickly and efficiently so that it is transmitted directly to the pots and pans, keeping the rest of the hob relatively cool. This makes it both



safe and energy efficient. Glass-ceramic is the only material suitable for all kinds of heating technologies - ceramic, induction and gas.

Induction hobs

Not only is an induction hob quick to reach temperature by heating the pan directly through electromagnetic induction, it also reduces the energy losses associated with heat escape making it more accurate to control. Choose induction for quicker cooking, an easy to clean hob surface and precision control.

The specific requirement for cooking on an induction hob is that only ferromagnetic pans will work (a magnet will stick to the base of the pan if it is compatible with induction hobs). High quality, flat based pans work best with induction and new pans will carry this symbol on the packaging to show they can be used:



Quick guide to gas hobs

Our range of gas hobs offers a wide choice. This comprehensive collection includes 1 and 2 burner domino hobs, functional 4 burner hobs and stunning 5 and 6 burner hobs for the most professional kitchen.

We have included beautiful, solid cast iron pan supports as standard with most of our hobs, whilst the HCG301, HG6150 and HG6250 have enamelled pan supports if you prefer a dishwasherable option.



All CDA gas hobs have automatic ignition and a flame failure safety device "Flame Safe" as standard.

Flame Safe is a feature designed to close off the gas supply in the event that a burner is accidentally extinguished.



HCG301

- 2 burners
 - Enamel pan support
 - Front control
- More details on p66

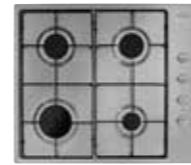

HG6150

- 4 burners
 - Enamel pan supports
 - Side control
- More details on p66



HG6250

- 4 burners
 - Enamel pan supports
 - Wok burner
 - Front control
 - Available in stainless steel and black
- More details on p67



HG6350

- 4 burners
 - Cast iron pan supports
 - Wok burner
 - Front control
- More details on p67



HG7250

- 5 burners
 - Cast iron pan supports
 - Wok burner
 - Front control
- More details on p68



HG7350

- 5 burners
 - Cast iron pan supports
 - Wok burner
 - Front control
- More details on p68

Gas



HG7500

- 4 burners
 - Cast iron pan supports
 - 2 wok burners (1 dual control)
 - Front control
- More details on p69



HG9350

- 5 burners
 - Cast iron pan supports
 - Wok burner
 - Front control
- More details on p69

Gas



HG9320

- 6 burners
 - Cast iron pan supports
 - Wok burner
 - Side control
- More details on p70

Gas on glass



HG3601

- Single burner gas on glass
 - Cast iron pan support
 - Wok burner
 - Front control
- More details on p70



HG3602

- 2 burner gas on glass
 - Cast iron pan supports
 - Front control
- More details on p71

Gas on glass



HVG66

- 4 burner gas on glass
 - Cast iron pan supports
 - Front control
- More details on p73



HVG77

- 5 burner gas on glass
 - Cast iron pan supports
 - Wok burner
 - Front control
- More details on p73



HVG96

- 5 burner gas on glass
 - Cast iron pan supports
 - Wok burner
 - Front control
- More details on p74



HVG93

- 4 burner gas on glass
 - Cast iron pan supports
 - Wok burner
 - Front control
- More details on p75

Gas on glass



HVG620

- 4 burner gas on glass
 - Cast iron pan supports
 - Front control
 - Available in stainless steel and black
- More details on p71



HVG720

- 5 burner gas on glass
 - Cast iron pan supports
 - Wok burner
 - Front control
 - Available in stainless steel and black
- More details on p72

Electric hobs

See pages 76-87 for all of our electric, ceramic and induction hobs.



HCG301
Domino two burner gas hob

- Features
- Front control
 - Enamel pan support
 - Automatic ignition
 - Flame failure safety device included

- Accessories
- LPG conversion kit included

- Available in
- Stainless steel

- Technical specification
- Burners:
- Front, semi-rapid: 1.75kW
 - Rear, rapid: 3kW
 - Rated gas input: 4.75kW
 - Rated electrical power: 1W
 - Power supply required: 3A

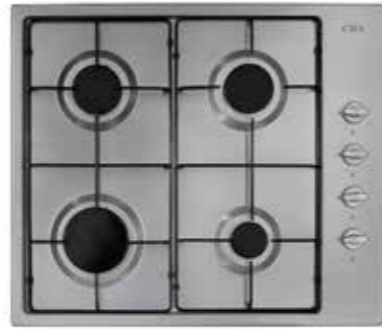
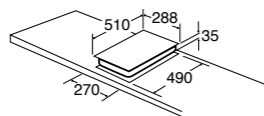

HG6150
Four burner gas hob

- Features
- Side control
 - Enamel pan supports
 - Automatic ignition
 - Flame failure safety device included

- Accessories
- LPG conversion kit included

- Available in
- Stainless steel

- Technical specification
- Burners:
- Front left, rapid: 3kW
 - Front right, auxiliary: 1kW
 - Rear left, semi-rapid: 1.75kW
 - Rear right, semi-rapid: 1.75kW
 - Rated gas input: 7.5kW
 - Rated electrical power: 1W
 - Power supply required: 3A

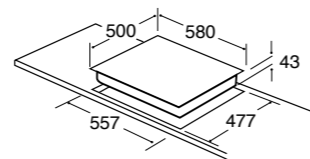

Stainless steel

HG6250
Four burner gas hob

- Features
- Front control
 - Enamel pan supports
 - Automatic ignition
 - Flame failure safety device included
 - Wok burner

- Accessories
- LPG conversion kit included

- Available in
- Stainless steel
 - Black

- Technical specification
- Burners:
- Front left, triple ring/wok: 3.8kW
 - Front right, auxiliary: 1kW
 - Rear left, semi-rapid: 1.75kW
 - Rear right, semi-rapid: 1.75kW
 - Rated gas input: 8.3kW
 - Rated electrical power: 1W
 - Power supply required: 3A

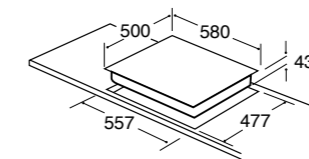

HG6350
Four burner gas hob

- Features
- Front control
 - Cast iron pan supports
 - Automatic ignition
 - Flame failure safety device included
 - Wok burner

- Accessories
- Wok support
 - LPG conversion kit included

- Available in
- Stainless steel
 - LPG gas version, HG6350LSS

- Technical specification
- Burners:
- Front left, triple ring/wok: 3.8kW
 - Front right, auxiliary: 1kW
 - Rear left, semi-rapid: 1.75kW
 - Rear right, semi-rapid: 1.75kW
 - Rated gas input: 8.3kW
 - Rated electrical power: 1W

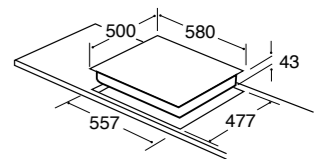

- Power supply required: 3A



HG7250
Five burner gas hob

Features

- Front control
- Cast iron pan supports
- Automatic ignition
- Flame failure safety device included
- Wok burner

Accessories

- Wok support
- LPG conversion kit included

Available in

- Black

Technical specification

Burners:

- Front left, semi-rapid: 1.75kW
- Front right, auxiliary: 1kW
- Centre, triple ring/wok: 3.8kW
- Rear left, semi-rapid: 1.75kW
- Rear right, rapid: 3kW
- Rated gas input: 11.3kW
- Rated electrical power: 2W

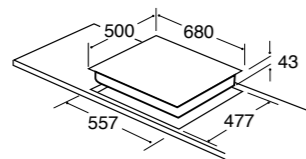

- Power supply required: 3A



HG7350
Five burner gas hob

Features

- Front control
- Cast iron pan supports
- Automatic ignition
- Flame failure safety device included
- Wok burner

Accessories

- Wok support
- LPG conversion kit included

Available in

- Stainless steel

Technical specification

Burners:

- Front left, semi-rapid: 1.75kW
- Front right, auxiliary: 1kW
- Centre, triple ring/wok: 3.8kW
- Rear left, semi-rapid: 1.75kW
- Rear right, rapid: 3kW
- Rated gas input: 11.3kW
- Rated electrical power: 2W

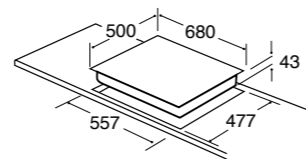

- Power supply required: 3A



HG7500
Four burner gas hob

Features

- 2 wok burners (1 dual control)
- Front control
- Cast iron pan supports
- Automatic ignition
- Flame failure safety device included

Accessories

- Wok support (not shown)
- LPG conversion kit included

Available in

- Stainless steel

Technical specification

Burners:

- Rear central, semi-rapid: 1.75kW
- Right, triple ring/wok: 3.5kW
- Front central, auxiliary: 1kW
- Left, dual burner: 4.2kW
- Rated gas input: 10.45kW
- Rated electrical power: 1W
- Power supply required: 3A

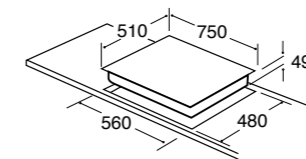

HG9350
Five burner gas hob

Features

- Wok burner
- Front control
- Cast iron pan supports
- Automatic ignition
- Flame failure safety device included

Accessories

- Wok support
- LPG conversion kit included

Available in

- Stainless steel

Technical specification

Burners:

- Front central, auxiliary: 1kW
- Front right, semi-rapid burner: 1.75kW
- Left, wok burner: 3.8kW
- Rear central, rapid burner: 3kW
- Rear right, semi-rapid: 1.75kW
- Rated gas input: 11.3kW
- Rated electrical power: 2W

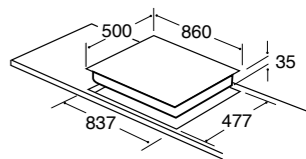

- Power supply required: 3A



HG9320
Six burner gas hob

- Features
- Wok burner
 - Side control
 - Cast iron pan supports
 - Automatic ignition
 - Flame failure safety device included

- Accessories
- Wok support
 - LPG conversion kit included

- Available in
- Stainless steel

- Technical specification
- Burners:
- Front left, triple ring/wok: 3.5kW
 - Front centre, auxiliary: 1kW
 - Front right, auxiliary: 1kW
 - Rear left, semi-rapid: 1.75kW
 - Rear centre, rapid: 3kW
 - Rear right, semi-rapid: 1.75kW
 - Rated gas input: 12kW

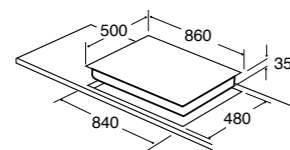

- Rated electrical power: 1.1W
- Power supply required: 3A

HG3601
Domino single burner gas on glass hob

- Features
- Wok burner
 - Front control
 - Cast iron pan supports
 - Automatic ignition
 - Flame failure safety device included

- Accessories
- Wok support (not shown)
 - LPG conversion kit included

- Available in
- Frameless

- Technical specification
- Burner:
- Centre, triple ring/wok: 3.5kW
 - Rated gas input: 3.5kW
 - Rated electrical power: 1W
 - Power supply required: 3A

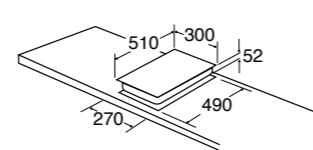

HG3602
Domino two burner gas on glass hob

- Features
- Front control
 - Cast iron pan supports
 - Automatic ignition
 - Flame failure safety device included

- Accessories
- LPG conversion kit included

- Available in
- Frameless

- Technical specification
- Burners:
- Front, semi-rapid: 1.75kW
 - Rear, rapid: 3kW
 - Rated gas input: 4.75kW
 - Rated electrical power: 1W
 - Power supply required: 3A

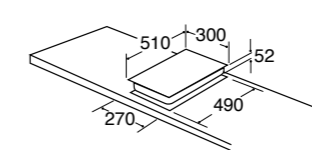

Black

Bevelled glass edges



Stainless steel

HVG620
Four burner gas on glass hob

- Features
- Bevelled edges
 - Front control
 - Cast iron pan supports
 - Automatic ignition
 - Flame failure safety device included

- Accessories
- LPG conversion kit included

- Available in
- Stainless steel
 - Black

- Technical specification
- Burners:
- Front left, rapid: 3kW
 - Front right, auxiliary: 1kW
 - Rear left, semi-rapid: 1.75kW
 - Rear right, semi-rapid: 1.75kW
 - Rated gas input: 7.5kW
 - Rated electrical power: 1.1W
 - Power supply required: 3A

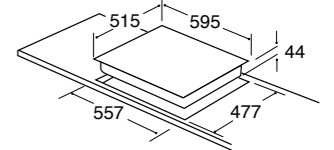



Black



Stainless steel

Bevelled glass edges

HVG720 Five burner gas on glass hob

- Features
- Bevelled edges
 - Front control
 - Wok burner
 - Cast iron pan supports
 - Automatic ignition
 - Flame failure safety device included

- Accessories
- Wok support (not shown)
 - LPG conversion kit included

- Available in
- Stainless steel
 - Black

- Technical specification
- Burners:
- Front left, auxiliary: 1kW
 - Front right, semi-rapid: 1.75kW
 - Centre, wok: 3.8kW
 - Rear left, rapid: 3kW
 - Rear right, semi-rapid: 1.75kW
 - Rated gas input: 11.3kW

- Rated electrical power: 1.1W
- Power supply required: 3A

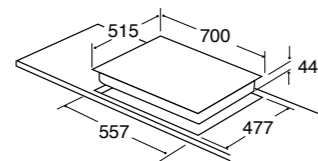

HVG66 Four burner gas on glass hob

- Features
- Front control
 - Cast iron pan supports
 - Automatic ignition
 - Flame failure safety device included

- Accessories
- Wok support (not shown)
 - LPG conversion kit included

- Available in
- Black

- Technical specification
- Burners:
- Front left, auxiliary: 1kW
 - Front right, semi-rapid: 1.75kW
 - Rear left, rapid: 3kW
 - Rear right, semi-rapid: 1.75kW
 - Rated gas input: 7.5kW
 - Rated electrical power: 1W
 - Power supply required: 3A

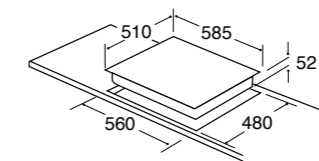

HVG77 Five burner gas on glass hob

- Features
- Wok burner
 - Front control
 - Cast iron pan supports
 - Automatic ignition
 - Flame failure safety device included

- Accessories
- Wok support
 - LPG conversion kit included

- Available in
- Black

- Technical specification
- Burners:
- Front left, rapid: 3kW
 - Front right, auxiliary: 1kW
 - Centre, wok: 3.5kW
 - Rear left, semi-rapid: 1.75kW
 - Rear right, semi-rapid: 1.75kW
 - Rated gas input: 11kW
 - Rated electrical power: 1W
 - Power supply required: 3A

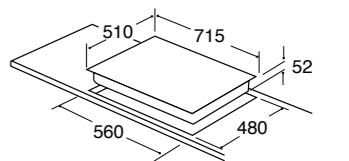



HVG96 Five burner gas on glass hob

Features

- Wok burner
- Front control
- Cast iron pan supports
- Automatic ignition
- Flame failure safety device included

Accessories

- Wok support (not shown)
- LPG conversion kit included

Available in

- Black

Technical specification

- Burners:**
- Front left, rapid: 3kW
 - Front centre, auxiliary: 1kW
 - Centre right, wok: 3.5kW
 - Rear left, semi-rapid: 1.75kW
 - Rear centre, semi-rapid: 1.75kW
 - Rated gas input: 11kW
 - Rated electrical power: 1W
 - Power supply required: 3A

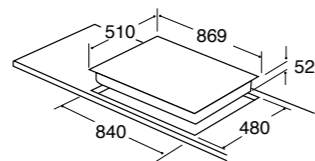

HVG93 Four burner gas on glass hob

Features

- Wok burner
- Front control
- Cast iron pan supports
- Automatic ignition
- Flame failure safety device included

Accessories

- Wok support (not shown)
- LPG conversion kit included

Available in

- Black

Technical specification

- Burners:**
- Left, wok: 3.5kW
 - Centre left, auxiliary: 1kW
 - Centre right, semi-rapid: 1.75kW
 - Right, rapid: 3kW
 - Rated gas input: 9.25kW
 - Rated electrical power: 1W
 - Power supply required: 3A



Co-ordinating products

This hob matches the 3D9 and EDD91 downdraft extractors.

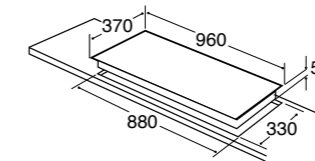

Quick guide to electric hobs

Our range of electric hobs includes a comprehensive selection of both manual and touch control 2, 4 and 5 zone ceramic hobs, high-tech induction hobs and domino hobs which you can put together in different combinations to suit your requirements.

All CDA ceramic and induction hobs have the following features:

- Easy clean surface
- Shatterproof ceramic safety glass
- Residual heat indicators

Domino



HCC310

- Griddle domino hob
- Front control
- Stainless steel
- More details on p78



HE3140

- 2 plate electric domino hob
- Front control
- Stainless steel
- More details on p78

Electric



HE6051

- 4 plate electric hob
- Side control
- Stainless steel
- More details on p79

Ceramic



HC3621

- 2 zone ceramic domino hob
- Front touch control
- More details on p79

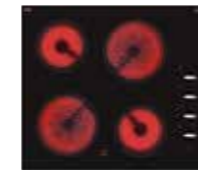

HC6211

- 4 zone ceramic hob
- Side control
- More details on p80

Ceramic

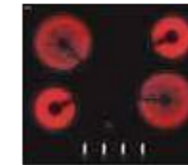

HC6311

- 4 zone ceramic hob
- Front control
- More details on p80

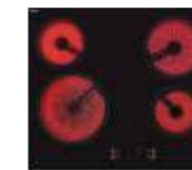

HC6621

- 4 zone ceramic hob
- Front touch control
- More details on p81

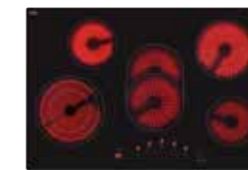

HC7621

- 5 zone ceramic hob
- Front touch control
- More details on p81



HC9621

- 5 zone ceramic hob
- Front touch control
- More details on p82

Ceramic



HC9606

- 4 zone ceramic hob
- Front touch control
- More details on p82

Induction



HN3621

- 2 zone domino induction hob
- Front touch control
- More details on p83



HN6111

- 4 zone induction hob
- Front touch control
- More details on p83



HN6411

- 4 zone eco induction hob
- Front touch control
- More details on p84



HN6731

- 4 zone induction hob
- Front touch control
- Bridging function
- More details on p84



HN6841

- 4 zone induction hob
- Front touch control
- Bridging function
- Illuminated front edge
- More details on p85

Induction



HN9611

- 5 zone induction hob
- Front touch control
- Bridging function
- More details on p86



HN9626

- 4 zone linear induction hob
- Front touch control
- More details on p87





HCC310
Domino griddle hob

Features

- Front control
- Single ceramic griddle - cook directly on glass
- 12 power levels with indicator light
- Easy clean surface

Optional accessories

- Domino joining strip, AHJ30

Available in

- Stainless steel

Technical specification

- Rated electrical power: 1.3kW
- Power supply required: 13A

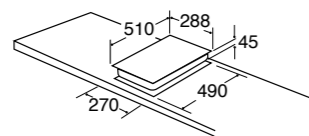

HE3140
Domino two plate electric hob

Features

- Front control
- 6 power levels with indicator light
- 1 rapid plates

Available in

- Stainless steel

Technical specification

Zones:

- Front, 145mm: 1kW
- Rear, 180mm rapid: 2kW
- Rated electrical power: 3kW
- Power supply required: 13A

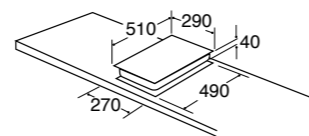

HE6051
Four plate electric hob

Features

- Side control
- 6 power levels with indicator light
- 2 rapid plates

Available in

- Stainless steel

Technical specification

Hot plates:

- Front left, 180mm rapid: 2kW
- Front right, 145mm: 1kW
- Rear left, 145mm rapid: 1.5kW
- Rear right, 180mm rapid: 1.5kW
- Rated electrical power: 6.0kW
- Power supply required: 30A

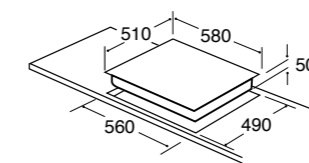

HC3621
Domino two zone ceramic hob

Features

- Front control
- Electronic touch control
- LED display
- 9 power levels
- 99 minute timer
- Safety key lock
- Residual heat indicators
- Easy clean surface
- Ceramic shatterproof safety glass
- Overflow detection
- Overheat detection
- Auto safety switch off
- Time limit security system
- Temperature limiter

Available in

- Frameless

Technical specification

Zones:

- Front, 145mm: 1.2kW
- Rear, 180mm: 1.8kW
- Rated electrical power: 3kW
- Power supply required: 13A

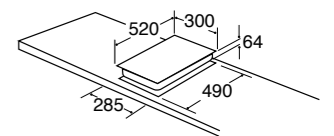

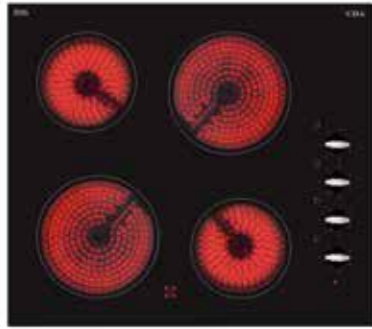

HC6211
Four zone ceramic hob

Features

- Side control
- 6 power levels with indicator light
- Residual heat indicators
- Easy clean surface
- Ceramic shatterproof safety glass
- Temperature limiter

Available in

- Frameless

Technical specification

Zones:

- Front left, 180mm: 1.8kW
- Front right, 145mm: 1.2kW
- Rear left, 145mm: 1.2kW
- Rear right, 180mm: 1.8kW
- Rated electrical power: 6.0kW
- Power supply required: 30A

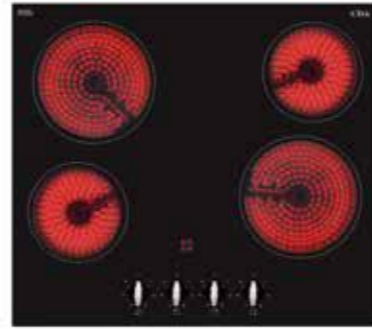
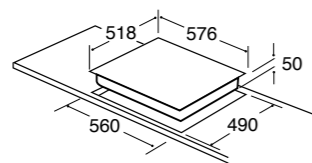

HC6311
Four zone ceramic hob

Features

- Front control
- 6 power levels with indicator light
- Residual heat indicators
- Easy clean surface
- Ceramic shatterproof safety glass
- Temperature limiter

Available in

- Frameless

Technical specification

Zones:

- Front left, 180mm: 1.8kW
- Front right, 145mm: 1.2kW
- Rear left, 145mm: 1.2kW
- Rear right, 180mm: 1.8kW
- Rated electrical power: 6.0kW
- Power supply required: 30A

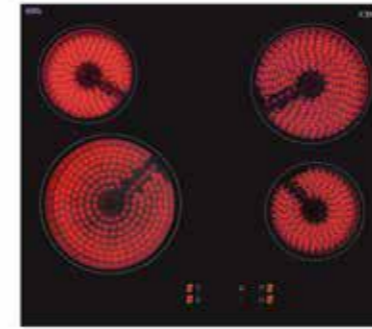
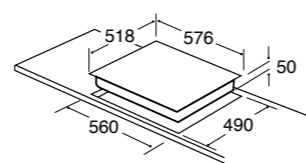

HC6621
Four zone ceramic hob

Features

- Front control
- Electronic touch control
- LED display
- 9 power levels
- Safety key lock
- Residual heat indicators
- Easy clean surface
- Ceramic shatterproof safety glass
- Overflow detection
- Overheat detection
- Auto safety switch off
- Time limit security system
- Temperature limiter

Available in

- Frameless

Technical specification

Zones:

- Front left, 210mm: 2.3kW
- Front right, 145mm: 1.2kW
- Rear left, 145mm: 1.2kW
- Rear right, 180mm: 1.8kW
- Rated electrical power: 6.5kW
- Power supply required: 30A

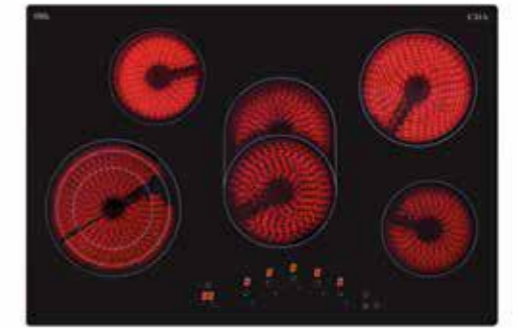
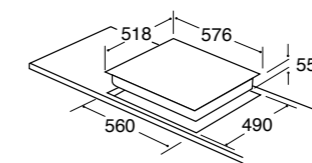

HC7621
Five zone ceramic hob

Features

- Front control
- Electronic touch control
- LED display
- 9 power levels
- 99 minute timer
- Safety key lock
- Residual heat indicators
- Easy clean surface
- Ceramic shatterproof safety glass
- Overflow detection
- Overheat detection
- Auto safety switch off
- Time limit security system
- Temperature limiter

Available in

- Frameless

Technical specification

Zones:

- Front left (triple):
 - 120mm: 0.8kW
 - 175mm: 1.6kW
 - 210mm: 2.3kW
- Front right, 145mm: 1.2kW
- Centre (dual):
 - 170mm: 1.5kW
 - 256mm: 2.2kW
- Rear left, 145mm: 1.2kW
- Rear right, 180mm: 1.8kW
- Rated electrical power: 8.7kW
- Power supply required: 40A

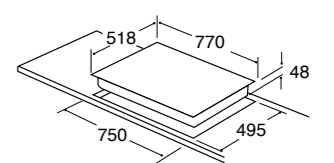

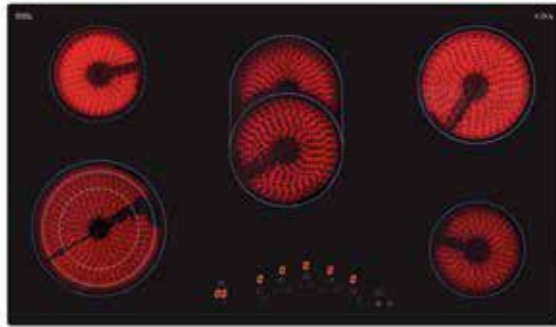

HC9621
Five zone ceramic hob

Features

- Front control
- Electronic touch control
- LED display
- 9 power levels
- 99 minute timer
- Safety key lock
- Residual heat indicators
- Easy clean surface
- Ceramic shatterproof safety glass
- Overflow detection
- Overheat detection
- Auto safety switch off
- Time limit security system
- Temperature limiter

Available in

- Frameless

Technical specification

Zones:

- Front left (triple):
 - 120mm: 0.8kW
 - 175mm: 1.6kW
 - 210mm: 2.3kW
- Front right, 145mm: 1.2kW
- Centre (dual):
 - 170mm: 1.5kW
 - 256mm: 2.2kW
- Rear left, 145mm: 1.2kW
- Rear right, 180mm: 1.8kW
- Rated electrical power: 8.7kW
- Power supply required: 40A

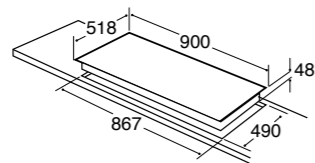

HC9606
Four zone ceramic linear hob

Features

- Front control
- Electronic touch control
- LED display
- 9 power levels
- 99 minute timer
- Safety key lock
- Residual heat indicators
- Easy clean surface
- Ceramic shatterproof safety glass
- Overflow detection
- Overheat detection
- Auto safety switch off
- Time limit security system
- Temperature limiter

Available in

- Frameless

Technical specification

Zones:

- Front left (triple):
 - 120mm: 0.8kW
 - 175mm: 1.6kW
 - 210mm: 2.3kW
- Centre left, 145mm: 1.2kW
- Centre right (dual):
 - 120mm: 0.7kW
 - 180mm: 1.7kW
- Front right, 145mm: 1.2kW
- Rated electrical power: 6.9kW
- Power supply required: 30A

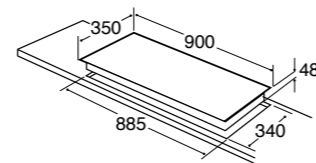

HN3621
Domino two zone induction hob

Features

- Front control
- Electronic touch control
- LED display
- 9 power levels
- 99 minute timer
- Safety key lock
- Residual heat indicators
- Keep warm function
- Easy clean surface
- Ceramic shatterproof safety glass
- Overflow detection
- Overheat detection
- Automatic pan detection
- Small object detection
- Auto safety switch off
- Time limit security system
- Temperature limiter

Available in

- Frameless

Technical specification

Zones:

- Front, 160mm: 1.4kW
- Rear, 160mm: 1.4kW
- Rated electrical power: 2.8kW
- Power supply required: 13A

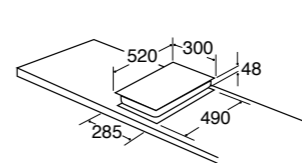

Fitting note

- Please ensure that you check that there is sufficient clearance when fitting induction hobs over both single and built-under double ovens and that adequate ventilation is provided.



HN6111
Four zone induction hob

Features

- Front control
- Electronic touch control
- LED display
- 9 power levels
- Booster function on all zones
- 99 minute timer
- Safety key lock
- Residual heat indicators
- Keep warm function
- Easy clean surface
- Ceramic shatterproof safety glass
- Overflow detection
- Overheat detection
- Automatic pan detection
- Small object detection
- Auto safety switch off
- Time limit security system
- Temperature limiter

Available in

- Frameless

Technical specification

Zones:

- Front left, 210mm: 2kW, 3kW with booster
- Front right, 160mm: 1.2kW, 1.4kW with booster
- Rear left, 160mm: 1.2kW, 1.4kW with booster
- Rear right, 210mm: 2kW, 3kW with booster
- Rated electrical power: 7.4kW
- Power supply required: 32A

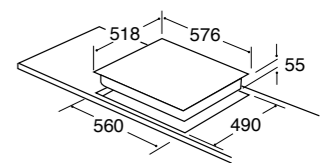

Fitting note

- Please ensure that you check that there is sufficient clearance when fitting induction hobs over both single and built-under double ovens and that adequate ventilation is provided.



HN6411
Four zone eco induction hob

- Features
- Front control
 - Electronic touch control
 - LED display
 - 9 power levels
 - Booster function on all zones
 - 99 minute timer
 - Safety key lock
 - Residual heat indicators
 - Power share system
 - Easy clean surface
 - Ceramic shatterproof safety glass
 - Overflow detection
 - Overheat detection
 - Automatic pan detection
 - Small object detection
 - Auto safety switch off
 - Time limit security system
 - Temperature limiter

- Available in
- Frameless

- Technical specification
Zones:
- Front left, 210mm: 1.5kW, 2kW with booster
 - Front right, 145mm: 1.2kW, 1.6kW with booster
 - Rear left, 145mm: 1.2kW, 1.6kW with booster
 - Rear right, 210mm: 1.5kW, 2kW with booster
 - Rated electrical power: 2.8/3.5/6/7.2kW (configurable)

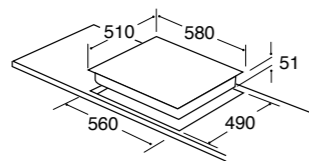

- Power supply required: 13-32A (configurable)
- If the hob is configured for use with a supply below 32A, the hob will automatically regulate the power consumption so as not to exceed the power available.

- Fitting note
- Please ensure that you check that there is sufficient clearance when fitting induction hobs over both single and built-under double ovens and that adequate ventilation is provided.

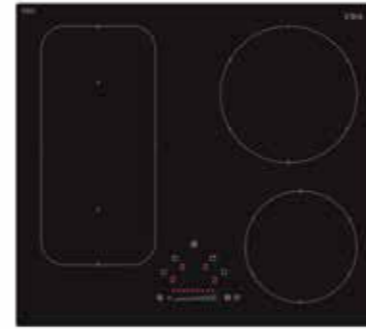

HN6731
Four zone induction hob

- Features
- Front control
 - Electronic touch and slide control
 - LED display
 - 9 power levels
 - Booster function on all zones
 - 99 minute timer
 - Safety key lock
 - Residual heat indicators
 - Pause/restart function
 - Keep warm function
 - Left zones bridging function
 - Easy clean surface
 - Ceramic shatterproof safety glass
 - Overflow detection
 - Overheat detection
 - Automatic pan detection
 - Small object detection
 - Time limit security system
 - Temperature limiter

- Available in
- Frameless

- Technical specification
Zones:
- Front left: 160mm, 1.4kW, 2kW with booster
 - Front right: 160mm, 1.2kW, 1.4kW with booster
 - Rear left: 160mm, 1.2kW, 1.4kW with booster
 - Rear right: 210mm, 2.3kW, 3kW with booster

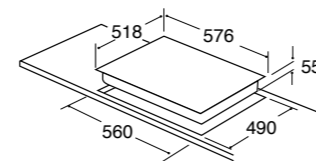

- Rated electrical power: 7.1kW
 - Power supply required: 32A
- Fitting note
- Please ensure that you check that there is sufficient clearance when fitting induction hobs over both single and built-under double ovens and that adequate ventilation is provided.



HN6841
Four zone induction hob with illuminated front edge

- Features
- Front control
 - Electronic touch and slide control
 - LED display
 - 9 power levels
 - Booster function on all zones
 - 99 minute timer
 - Safety key lock
 - Residual heat indicators
 - Illuminated front edge
 - Pause/restart function
 - Keep warm function
 - Melt function
 - Simmer function
 - Left zones can be bridged
 - Right zones can be bridged
 - Side bevelled edges
 - Easy clean surface
 - Ceramic shatterproof safety glass
 - Overflow detection
 - Overheat detection
 - Automatic pan detection
 - Small object detection
 - Auto safety switch off
 - Time limit security system
 - Temperature limiter

- Available in
- Frameless

- Technical specification
Zones:
- Front left: 220mm x 190mm, 2.2kW, 3.7kW with booster

- Front right: 220 x 190mm, 2.2kW, 3.7kW with booster
- Rear left: 220mm x 190mm, 2.2kW, 3.7kW with booster
- Rear right: 220 x 190mm, 2.2kW, 3.7kW with booster
- Rated electrical power: 7.4kW
- Power supply required: 32A

- Fitting note
- Please ensure that you check that there is sufficient clearance when fitting induction hobs over both single and built-under double ovens and that adequate ventilation is provided.



Illuminated front edge

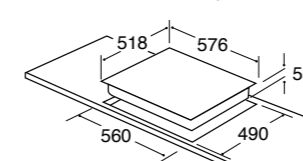

Melt function
Use the melt function to slowly warm delicate foods that are prone to burning, such as chocolate or butter.



HN9611 Five zone induction hob

Features

- Front control
- Electronic touch and slide control
- LED display
- 9 power levels
- Booster function on all zones
- 99 minute timer
- Safety key lock
- Residual heat indicators
- Pause/restart function
- Keep warm function
- Melt function
- Simmer function
- Left zones bridging function
- Right zones bridging function
- Easy clean surface
- Ceramic shatterproof safety glass
- Overflow detection
- Overheat detection
- Automatic pan detection
- Small object detection
- Auto safety switch off
- Time limit security system
- Temperature limiter

Available in

- Frameless

Technical specification

Zones:

- Front left: 210mm, 2.1kW, 3.7kW with booster
- Front right: 210mm, 2.1kW, 3.7kW with booster

- Centre: 260mm, 2.6kW, 3.7kW with booster
- Rear left: 210mm, 2.1kW, 3.7kW with booster
- Rear right: 210mm, 2.1kW, 3.7kW with booster
- Rated electrical power: 11.1kW
- Power supply required: 45A

Fitting note

- Please ensure that you check that there is sufficient clearance when fitting induction hobs over both single and built-under double ovens and that adequate ventilation is provided.

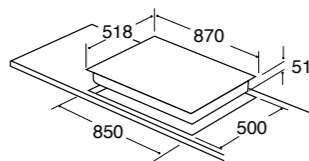

HN9626 Four zone linear induction hob

Features

- Front control
- Electronic touch and slide control
- LED display
- 9 power levels
- Booster function on all zones
- 99 minute timer
- Safety key lock
- Residual heat indicators
- Pause/restart function
- Keep warm function
- Easy clean surface
- Ceramic shatterproof safety glass
- Overflow detection
- Overheat detection
- Automatic pan detection
- Small object detection
- Auto safety switch off

Available in

- Frameless

Technical specification

Zones:

- Front left, 220mm: 2.3kW, 3kW with booster
- Centre left, 180mm: 1.2kW, 1.4kW with booster
- Centre right, 180mm: 1.2kW, 1.4kW with booster
- Front right, 220mm: 2.3kW, 3kW with booster
- Rated electrical power: 7.4kW
- Power supply required: 32A

Fitting note

- Please ensure that you check that there is sufficient clearance when fitting induction hobs over both single and built-under double ovens and that adequate ventilation is provided.

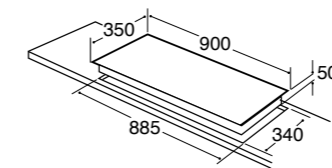

Keep your kitchen smelling fresh and clean with one of our stylish extractors.

Extractors

As well as keeping your kitchen fresh, a stylish CDA extractor will provide a focal point, adding impact to the overall design.



Ducted/re-circulating

Choose between ducting your extractor outside or recirculating filtered, cleaned air back into your kitchen with the CDA extractor range. We provide a comprehensive range of ducting kits and charcoal filters, listed on our accessories pages, to support your preference.



Design

Whether you are looking for a space-saving angled design or a statement island hood, our range of extractors offer a choice of fitting styles and finishes that will perfectly complement your kitchen. Built using the highest quality steel, glass and aluminium, the extractor collection features sharp lines and elegant curves to bring out the unique elements of your home whilst offering quiet, powerful air filtration in the kitchen.

Choose from discreet ceiling editions that are installed out of view and are controlled remotely, or downdrafts that slip quietly away beneath your work surfaces.

Lighting

For ambient lighting in the kitchen our range of edge-lit extractors give you the option to switch on LED lighting in a range of colours as an extra design feature in your home. The EKP range are in a curved glass design, while the EKN models have flat glass, both come with the edge lighting detail.

For clear, ceiling height extraction and bright LED lighting take a look at the EVX101 and EVX110. As well as one of the most powerful extraction rates on the market it features low noise levels and user-friendly features for your convenience.



Automatic cut-off timer

The residual smells of cooking can leave a bad taste in the mouth and they don't stop being produced when the hob is switched off. That's why many touch control models offer an automatic cut-off timer to continue working until the residual steam and odours are removed from your home.

Quick guide to extractors

Our extensive range of extractors includes integrated and under canopy models, together with a great selection of stylish, contemporary chimney and island extractors for a chic design statement in your kitchen.

Most CDA extractor models have dishwasher aluminium grease filters.

Extraction and noise level measurements

The extraction rate and noise level measurements are displayed in accordance with EN61591 for extraction rates and EN60704 for noise levels. These measurements provide an approximation of real world performance when installed with recommended ducting kits.

Required distance between hob and extractor

Please refer to both your hob and extractor instructions before installation - for legal requirements, the distance between your hob and extractor should be determined by the maximum measurement provided.

Ducting advice

Using ducting of smaller diameter than that recommended may increase the noise level and can reduce the efficiency of your extractor. Where possible, always use the largest diameter ducting you can.

Functional



CST61

- Standard extractor
- Available in stainless steel or white
- More details on p92



EIN60

- Integrated extractor
- Available with acrylic or aluminium grease filters
- More details on p92



CCA5/7

- Under canopy extractor
- 50cm and 70cm wide
- More details on p93



ECP62/72/82/92/102/112

- Curved glass extractor
- 60cm, 70cm, 80cm, 90cm, 100cm and 110cm wide
- Available in stainless steel or black
- More details on p97



EKP60/70/90

- Curved glass island extractor
- 60cm, 70cm and 90cm wide with edge lighting
- Available in stainless steel or black
- More details on p97



ECPK90

- Curved glass island extractor
- 90cm wide
- More details on p98

Angled



ECA60

- Angled extractor
- 60cm wide
- More details on p103



EVA60/70/90

- Angled extractor
- 60cm, 70cm and 90cm wide
- More details on p103



EVG6/9

- Angled extractor
- 60cm and 90cm wide
- Available in stainless steel or black
- More details on p104

Cylinder



EVC41

- Cylinder extractor
- Available in stainless steel or black
- More details on p106



EVCK41

- Cylinder island extractor
- Available in stainless steel or black
- More details on p107

Statement



EVQ71

- Circular extractor
- More details on p110



3U10

- Updraft extractor
- More details on p110



3S10

- Spherical extractor
- Available in white or black
- More details on p111

Chimney



CTE61

- Telescopic extractor
- 60cm wide
- More details on p94



CTE9

- Telescopic extractor
- 90cm wide
- More details on p94



ECH61/71/91/101

- Chimney extractor
- 60cm, 70cm, 90cm and 100cm wide
- Available in stainless steel or black
- More details on p95



ECHK90

- Chimney island extractor
- 90cm wide
- More details on p95



ECR90

- Traditional chimney extractor
- 90cm wide
- Available in cream or black
- More details on p96



EKPK90

- Curved glass island extractor with edge lighting
- 90cm wide
- Available in stainless steel or black
- More details on p99



ECN62/72/92

- Flat glass extractor
- 60cm, 70cm and 90cm wide
- Available in stainless steel or black
- More details on p100



EKN60/70/90

- Flat glass extractor with edge lighting
- 60cm, 70cm and 90cm wide
- Available in stainless steel or black
- More details on p101



EVPC91

- Corner chimney extractor
- More details on p102



EXA60/80

- Angled extractor
- 60cm and 80cm wide
- Available in silver or black
- More details on p105

Linear



EVP61/91/101/121

- Linear extractor
- 60cm, 90cm, 100cm and 120cm wide
- More details on p108



EVPK90

- Linear island extractor
- 90cm wide
- More details on p109

Ceiling



EVX101

- Ceiling extractor
- 100cm wide
- More details on p112



EVX110

- Ceiling extractor
- 110cm wide
- More details on p113

Downdraft



EDD61/91

- Downdraft extractor
- 60cm and 90cm wide
- More details on p114



3D9

- Downdraft extractor
- 90cm wide
- More details on p115



Stainless steel



CCA5 - 50cm wide



White



CCA7 - 70cm wide

CST61 Standard extractor

- Features**
- Ducted/re-circulating installation
 - 3 speeds
 - Push button control
 - Aluminium grease filter
 - 1 x 28W halogen light
 - Glass light diffuser

- Optional accessories**
- Ducting kit, AED51/53/54
 - Charcoal filter for re-circulation, CHA5 (pack of 1)

- Available in**
- Stainless steel
 - White

- Technical specification**
- Required height over gas hob: 700mm (min)
 - Required height over electric hob: 600mm (min)
 - Outlet diameter: 120mm
 - Noise level: 63dBA
 - Extraction rate: 175m³/h
 - Rated electrical power: 83W

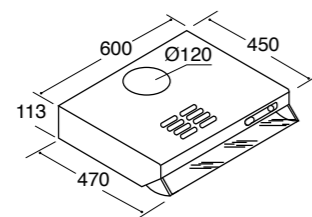

EIN60 Integrated extractor

- Features**
- Ducted/re-circulating installation
 - 3 speeds
 - Slider control
 - 1 x 28W halogen light

- Optional accessories**
- Ducting kit, AED51/53/54
 - Charcoal filter for re-circulation, CHA15 (pack of 1)
 - Aluminium grease filter, GRE3M
 - Acrylic grease filter, GRE1

- Available in**
- Silver
 - Silver - with aluminium grease filter, EIN60FSI

- Technical specification**
- Required height over gas hob: 700mm (min)
 - Required height over electric hob: 600mm (min)
 - Outlet diameter: 120mm
 - Noise level: 62dBA

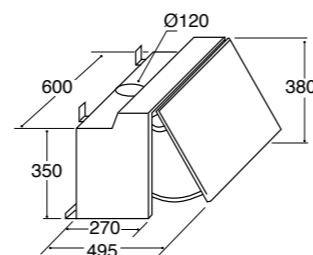

- Extraction rate:**
- EIN60: 197m³/h
 - EIN60FSI: 203m³/h
- Rated electrical power:** 148W
- Power supply required:** 3A

- Energy efficiency rating**
- Energy rating: D

CCA5/7 Canopy extractor

- Features**
- Ducted/re-circulating installation
 - 3 speeds
 - Slider control
 - CCA5 - acrylic grease filter
 - CCA7 - aluminium grease filter
 - 1 x 28W halogen light (CCA5)
 - 2 x 28W halogen lights (CCA7)
 - Glass light diffuser

- Optional accessories**
- Ducting kit, AED51/53/54
 - Charcoal filter for re-circulation:
 - CCA5, CHA1 (pack of 1)
 - CCA7, CHA21 (pack of 2)
 - CCA5, Aluminium grease filter, GRE2M
 - CCA5, Acrylic grease filter, GRE1

- Available in**
- CCA5 - silver or white
 - CCA7 - silver

- Technical specification**
- Required height over gas hob: 700mm (min)
 - Required height over electric hob: 600mm (min)
 - Outlet diameter: 120mm
 - Noise level:
 - CCA5: 65dBA
 - CCA7: 73dBA
 - Extraction rate:
 - CCA5: 195m³/h
 - CCA7: 313m³/h
 - Rated electrical power:
 - CCA5: 188W
 - CCA7: 216W
 - Power supply required: 3A

- Energy efficiency rating**
- Energy rating:
 - CCA5: D
 - CCA7: E

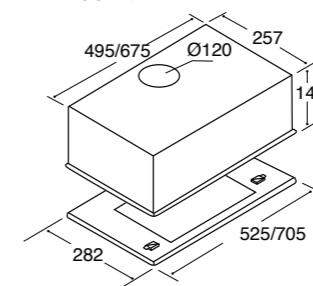



Open



Closed

CTE61
Telescopic extractor

- Features**
- Ducted/re-circulating installation
 - 3 speeds
 - Rocker switch
 - Aluminium grease filter
 - 2 x 3W LED lights
- Optional accessories**
- Ducting kit, AED51/53/54
 - Charcoal filter for re-circulation, CHA34 (pack of 2)
- Available in**
- Stainless steel
- Technical specification**
- Required height over gas hob: 750mm (min)
 - Required height over electric hob: 650mm (min)
 - Outlet diameter: 120mm
 - Noise level: 62dBA
 - Extraction rate: 316m³/h
 - Rated electrical power: 116W
 - Power supply required: 3A

- Energy efficiency rating**
- Energy rating: D

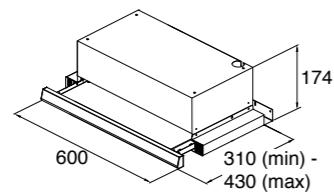

Open



Closed

CTE9
Telescopic extractor

- Features**
- Ducted/re-circulating installation
 - 3 speeds
 - Rocker switch
 - Aluminium grease filter
 - 2 x 3W LED lights
- Optional accessories**
- Ducting kit, AED51/53/54
 - Charcoal filter for re-circulation, CHA35 (pack of 2)
- Available in**
- Stainless steel
- Technical specification**
- Required height over gas hob: 750mm (min)
 - Required height over electric hob: 650mm (min)
 - Outlet diameter: 120mm
 - Noise level: 63dBA
 - Extraction rate: 367m³/h
 - Rated electrical power: 226W
 - Power supply required: 3A

- Energy efficiency rating**
- Energy rating: E

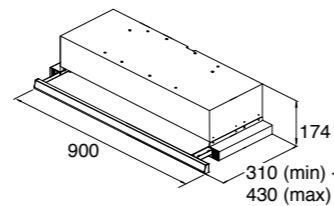

ECH61 - Stainless steel



ECH91 - Black

ECH61/71/91/101
Chimney extractor

- Features**
- Ducted/re-circulating installation
 - 3 speeds
 - Push button control
 - Aluminium grease filters
 - 2 x 50W halogen lights
 - Twin fan motor
- Optional accessories**
- Ducting kit, AED61/63/64
 - Charcoal filter for re-circulation, CHA24 (pack of 2)
- Available in**
- Stainless steel
 - Black
- Technical specification**
- Required height over gas hob: 700mm (min)
 - Required height over electric hob: 600mm (min)
 - Outlet diameter: 150mm
 - Noise level: 64dBA
 - Extraction rate: 427m³/h
 - Rated electrical power: 240W

- Power supply required: 3A
- Energy efficiency rating**
- Energy rating: E
- Fitting note**
- Please ensure that you check the ceiling height is sufficient to allow the required clearance between the hob and extractor.

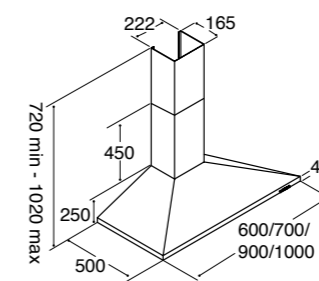

ECH61 - 60cm wide
ECH71 - 70cm wide
ECH91 - 90cm wide
ECH101 - 100cm wide



ECHK90
Chimney island extractor

- Features**
- Ducted/re-circulating installation
 - 3 speeds
 - Push button control
 - Aluminium grease filters
 - 2 x 2W LED lights
- Optional accessories**
- Ducting kits:
 - 120mm, AED51/53/54
 - 150mm, AED61/63/64
 - Charcoal filter for re-circulation, CHA25 (pack of 2)
- Available in**
- Stainless steel
- Technical specification**
- Required height over gas hob: 700mm (min)
 - Required height over electric hob: 600mm (min)
 - Outlet diameter: 120mm/150mm
 - Noise level: 61dBA
 - Extraction rate: 404m³/h

- Rated electrical power: 104W
 - Power supply required: 3A
- Energy efficiency rating**
- Energy rating: C
- Fitting note**
- Please ensure that you check the ceiling height is sufficient to allow the required clearance between the hob and extractor.

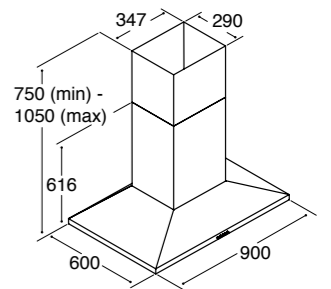



Cream



Black

ECR90
Traditional chimney extractor

- Features**
- Ducted/re-circulating installation
 - 3 speeds
 - Push button control
 - Aluminium grease filters
 - 2 x 2W LED lights
- Optional accessories**
- Ducting kit, AED61/63/64
 - Charcoal filter for re-circulation, CHA25 (pack of 2)
- Available in**
- Black
 - Cream
- Technical specification**
- Required height over gas hob: 700mm (min)
 - Required height over electric hob: 600mm (min)
 - Outlet diameter: 150mm
 - Noise level: 69dBA
 - Extraction rate: 543m³/h
 - Rated electrical power: 164W
 - Power supply required: 3A

- Energy efficiency rating**
- Energy rating: D
- Fitting note**
- Please ensure that you check the ceiling height is sufficient to allow the required clearance between the hob and extractor.

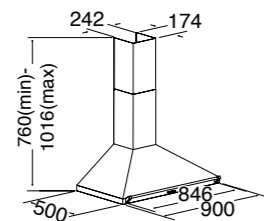

Co-ordinating products
This extractor matches the RVC931 range cooker.



- ECP62 - 60cm wide
- ECP72 - 70cm wide
- ECP82 - 80cm wide
- ECP92 - 90cm wide
- ECP102 - 100cm wide
- ECP112 - 110cm wide



The black ECP models have a smoked glass canopy

ECP62/72/82/92/102/112
Curved glass extractor

- Features**
- Ducted/re-circulating installation
 - 3 speeds
 - Push button control
 - Aluminium grease filters
 - 2 x 2W LED lights
- Optional accessories**
- Ducting kits:
 - 120mm, AED51/53/54
 - 150mm, AED61/63/64
 - Charcoal filter for re-circulation, CHA12 (pack of 1)
- Available in**
- Stainless steel
 - Black
- Technical specification**
- Required height over gas hob: 700mm (min)
 - Required height over electric hob: 600mm (min)
 - Outlet diameter: 120mm/150mm
 - Noise level: 60dBA
- Extraction rate:**
- ECP62/72/82: 391m³/h
 - ECP92/102/112: 377m³/h
- Rated electrical power:** 104W
- Power supply required:** 3A
- Energy efficiency rating**
- Energy rating: D
- Fitting note**
- Please ensure that you check the ceiling height is sufficient to allow the required clearance between the hob and extractor.

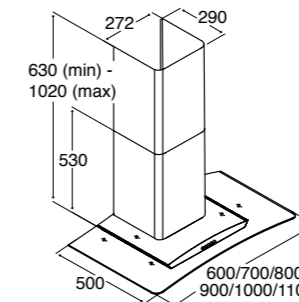

Red lighting Blue lighting Green lighting



- EKP60 - 60cm wide
- EKP70 - 70cm wide
- EKP90 - 90cm wide



Choose from red, blue or green lighting

EKP60/70/90
Curved glass extractor with edge lighting

- Features**
- Ducted/re-circulating installation
 - 3 speeds
 - Touch control
 - Aluminium grease filters
 - 2 x 2W LED lights
 - 3W of edge lighting
 - 9 minute timer
- Optional accessories**
- Ducting kits:
 - 120mm, AED51/53/54
 - 150mm, AED61/63/64
 - Charcoal filter for re-circulation, CHA17 (pack of 2)
- Available in**
- Stainless steel
 - Black
- Technical specification**
- Required height over gas hob: 700mm (min)
 - Required height over electric hob: 600mm (min)
 - Outlet diameter: 120mm
 - Noise level: 69dBA
- Extraction rate:** 336m³/h
- Rated electrical power:** 127W
- Power supply required:** 3A
- Energy efficiency rating**
- Energy rating: D
- Fitting note**
- Please ensure that you check the ceiling height is sufficient to allow the required clearance between the hob and extractor.

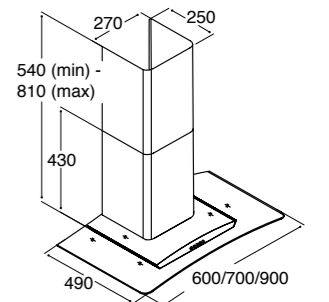



ECPK90
Curved glass island extractor

- Features**
- Ducted/re-circulating installation
 - 3 speeds
 - Push button control
 - Aluminium grease filters
 - 4 x 2W LED lights
- Optional accessories**
- Ducting kits:
 - 120mm, AED51/53/54
 - 150mm, AED61/63/64
 - Charcoal filter for re-circulation, CHA25 (pack of 2)
- Available in**
- Stainless steel

- Rated electrical power: 108W
 - Power supply required: 3A
- Energy efficiency rating**
- Energy rating: D

- Fitting note**
- Please ensure that you check the ceiling height is sufficient to allow the required clearance between the hob and extractor.

- Technical specification**
- Required height over gas hob: 700mm (min)
 - Required height over electric hob: 600mm (min)
 - Outlet diameter: 120mm/150mm
 - Noise level: 61dBA
 - Extraction rate: 387m³/h

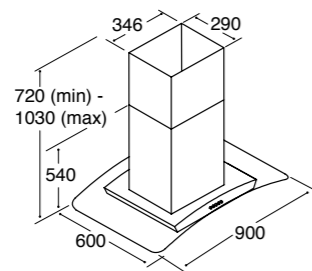

Stainless steel

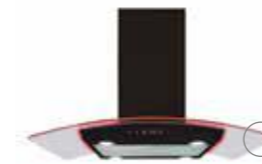

Choose from red, blue or green lighting

Black

EKPK90
Curved glass island extractor with edge lighting

- Features**
- Ducted/re-circulating installation
 - 3 speeds
 - Touch control
 - Aluminium grease filters
 - 4 x 2W LED lights
 - 3W of edge lighting
 - Timer function
- Optional accessories**
- Ducting kits:
 - 120mm, AED51/53/54
 - 150mm, AED61/63/64
 - Charcoal filter for re-circulation, CHA12 (pack of 1)
- Available in**
- Stainless steel
 - Black

- Noise level: 61dBA
- Extraction rate: 387m³/h
- Rated electrical power: 111W
- Power supply required: 3A

- Energy efficiency rating**
- Energy rating: D

- Fitting note**
- Please ensure that you check the ceiling height is sufficient to allow the required clearance between the hob and extractor.

- Technical specification**
- Required height over gas hob: 700mm (min)
 - Required height over electric hob: 600mm (min)
 - Outlet diameter: 120mm/150mm

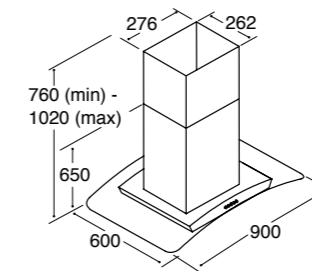



ECN62 - 60cm wide
ECN72 - 70cm wide
ECN92 - 90cm wide

ECN62 - Black

ECN62/72/92 Flat glass extractor

- Features
- Ducted/re-circulating installation
 - 3 speeds
 - Push button control
 - Aluminium grease filter
 - 2 x 2W LED lights

- Optional accessories
- Ducting kits:
 - 120mm, AED51/53/54
 - 150mm, AED61/63/64
 - Charcoal filter for re-circulation, CHA12 (pack of 1)

- Available in
- Stainless steel
 - Black

- Technical specification
- Required height over gas hob: 700mm (min)
 - Required height over electric hob: 600mm (min)
 - Outlet diameter 120mm/150mm
 - Noise level: 60dBA
 - Extraction rate: 391m³/h

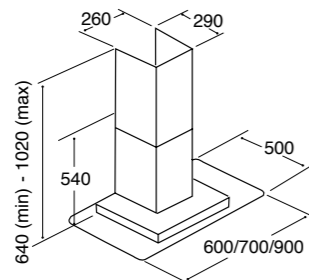

- Rated electrical power: 104W
- Power supply required: 3A

- Energy efficiency rating
- Energy rating: D

- Fitting note
- Please ensure that you check the ceiling height is sufficient to allow the required clearance between the hob and extractor.

LED lighting
As well as superb performance, the EKP range of extractors offers an extra aesthetic detail with edge lighting to make a real focal point in your kitchen.



EKN60 - 60cm wide
EKN70 - 70cm wide
EKN90 - 90cm wide

EKN90 - Black

EKN60/70/90 Flat glass extractor with edge lighting

- Features
- Ducted/re-circulating installation
 - 3 speeds
 - Touch control
 - Aluminium grease filter
 - 2 x 2W LED lights
 - 3W of edge lighting
 - Timer function

- Optional accessories
- Ducting kits:
 - 120mm, AED51/53/54
 - 150mm, AED61/63/64
 - Charcoal filter for re-circulation, CHA17 (pack of 2)

- Available in
- Stainless steel
 - Black

- Technical specification
- Required height over gas hob: 700mm (min)
 - Required height over electric hob: 600mm (min)
 - Outlet diameter 120mm/150mm

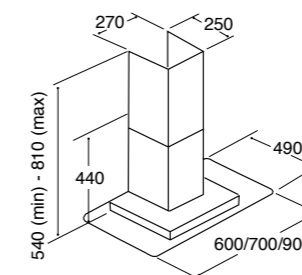

- Noise level: 69dBA
- Extraction rate: 336m³/h
- Rated electrical power: 127W
- Power supply required: 3A

- Energy efficiency rating
- Energy rating: D

- Fitting note
- Please ensure that you check the ceiling height is sufficient to allow the required clearance between the hob and extractor.

Choose from red, blue or green lighting



EVPC91
Corner extractor

- Features**
- Ducted/re-circulating installation
 - 3 speeds + intensive
 - Soft touch buttons
 - Aluminium grease filters
 - 4 x 20W halogen lights
 - Filter saturation warning light
 - Clean air function
 - Timer
- Optional accessories**
- Ducting kits:
 - 120mm, AED51/53/54
 - 150mm, AED61/63/64
 - Charcoal filter for re-circulation, CHA22 (pack of 1)
- Available in**
- Stainless steel
- Technical specification**
- Required height over gas hob: 750mm (min)
 - Required height over electric hob: 650mm (min)
- Outlet diameter**
120mm/150mm
- Noise level:** 64dBA
- Extraction rate:** 521m³/h
- Rated electrical power:** 355W
- Power supply required:** 3A
- Energy efficiency rating**
- Energy rating: C
- Fitting note**
- Please ensure that you check the ceiling height is sufficient to allow the required clearance between the hob and extractor.

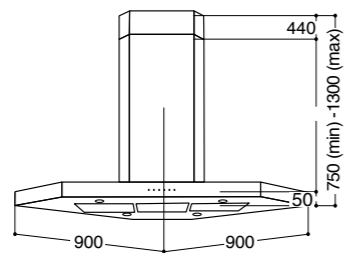

ECA60
Angled extractor

- Features**
- Ducted/re-circulating installation
 - 3 speeds
 - Push button control
 - Aluminium grease filter
 - 2 x 2W LED lights
 - Twin fan motor
- Optional accessories**
- Ducting kit, AED51/53/54
 - Charcoal filter for re-circulation, CHA15 (pack of 1)
- Available in**
- Black
- Technical specification**
- Required height over gas hob: 550mm (min)
 - Required height over electric hob: 550mm (min)
 - Outlet diameter: 120mm
 - Noise level: 64dBA
 - Extraction rate: 350m³/h
 - Rated electrical power: 114W
 - Power supply required: 3A
- Energy efficiency rating**
- Energy rating: B
- Fitting note**
- Please ensure that you check the ceiling height is sufficient to allow the required clearance between the hob and extractor.

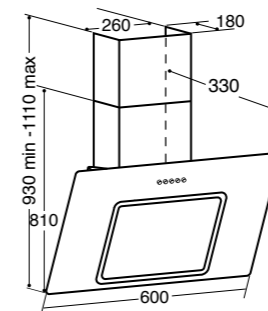

EVA60



EVA90

EVA60/70/90
Angled extractor

- Features**
- Ducted/re-circulating installation
 - 3 speeds
 - Touch control
 - Aluminium grease filter
 - 2 x 2W LED lights
 - Twin fan motor
 - 15 minute timer
- Optional accessories**
- Ducting kit, AED51/53/54
 - Charcoal filter for re-circulation, CHA15 (pack of 1)
- Available in**
- Black
- Technical specification**
- Required height over gas hob: 550mm (min)
 - Required height over electric hob: 550mm (min)
 - Outlet diameter: 120mm
 - Noise level: 64dBA
 - Extraction rate: 350m³/h
 - Rated electrical power: 114W
- Energy efficiency rating**
- Energy rating: B
- Fitting note**
- Please ensure that you check the ceiling height is sufficient to allow the required clearance between the hob and extractor.
- Power supply required:** 3A

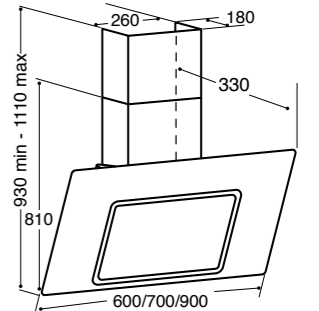

EVA60 - 60cm wide
EVA70 - 70cm wide
EVA90 - 90cm wide



EVG6 - Black

Black glass panel



EVG9 - Stainless steel

Clear glass panel

EVG6/9 Angled glass extractor

- Features**
- Ducted/re-circulating installation
 - 3 speeds + intensive
 - Touch control
 - Aluminium grease filter
 - 2 x 20W halogen lights
 - Twin fan motor
 - Filter saturation warning light
 - Clean air function
 - 15 minute timer
- Optional accessories**
- Ducting kit, AED61/63/64
 - Charcoal filter for re-circulation, CHA21 (pack of 2)
- Available in**
- Stainless steel
 - Black
- Technical specification**
- Required height over CDA gas hob: 450mm (min), otherwise 760mm (min)
 - Required height over CDA electric hob: 450mm (min), otherwise 650mm (min)
 - Outlet diameter: 150mm
 - Noise level: 58dBA
 - Extraction rate: 422m³/h
 - Rated electrical power: 290W
 - Power supply required: 3A
- Energy efficiency rating**
- Energy rating: D
- Fitting note**
- Please ensure that you check the ceiling height is sufficient to allow the required clearance between the hob and extractor.

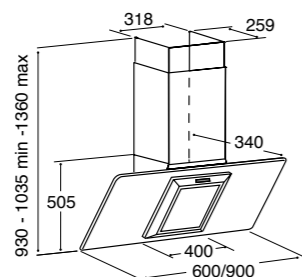

EXA80 - Stainless steel

EXA60 - 60cm wide
EXA80 - 80cm wide



EXA80 - Black

EXA60/80 Angled extractor

- Features**
- Ducted/re-circulating installation
 - 3 speeds + intensive
 - Touch control
 - Aluminium grease filter
 - 1 x 6.5W LED strip light
 - Filter saturation warning light
 - Timer function
- Optional accessories**
- Ducting kit, AED61/63/64
 - Charcoal filter for re-circulation, CHA14 (pack of 2)
 - Re-circulating T piece, RTP01
- Available in**
- Silver
 - Black
- Technical specification**
- Required height over gas hob: 650mm (min)
 - Required height over electric hob: 650mm (min)
 - Outlet diameter: 150mm
 - Noise level:
 - EXA60: 62dBA
 - EXA80: 59dBA
 - Extraction rate:
 - EXA60: 610m³/h
 - EXA80: 618m³/h
 - Rated electrical power: 282W
 - Power supply required: 3A
 - Supplied with a UK plug
- Energy efficiency rating**
- Energy rating: A
- Fitting note**
- Please ensure that you check the ceiling height is sufficient to allow the required clearance between the hob and extractor.

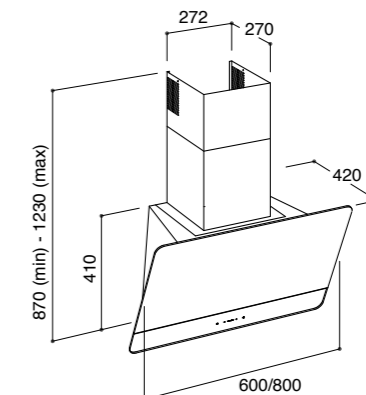



Stainless steel



Black (side view)

EVC41 Cylinder extractor

- Features**
- Ducted/re-circulating installation
 - 3 speeds + intensive
 - Soft touch buttons
 - Aluminium grease filter
 - 2 x 20W halogen lights
 - Filter saturation warning light
 - Clean air function
 - Timer function
- Outlet diameter**
120mm/150mm
- Noise level:** 60dBA
- Extraction rate:** 516m³/h
- Rated electrical power:** 315W
- Power supply required:** 3A
- Energy efficiency rating**
- Energy rating: B

- Optional accessories**
- Ducting kits:
 - 120mm, AED51/53/54
 - 150mm, AED61/63/64
 - Charcoal filter for re-circulation, CHA23 (pack of 1)

- Available in**
- Stainless steel
 - Black

- Technical specification**
- Required height over gas hob: 750mm (min)
 - Required height over electric hob: 650mm (min)

- Fitting note**
- Please ensure that you check the ceiling height is sufficient to allow the required clearance between the hob and extractor.

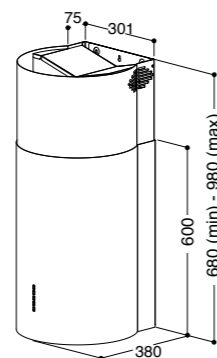

Stainless steel



Black

EVCK41 Cylinder island extractor

- Features**
- Ducted/re-circulating installation
 - 3 speeds + intensive
 - Soft touch buttons
 - Aluminium grease filter
 - 2 x 20W halogen lights
 - Filter saturation warning light
 - Clean air function
 - Timer function
- Outlet diameter**
120mm/150mm
- Noise level:** 60dBA
- Extraction rate:** 516m³/h
- Rated electrical power:** 315W
- Power supply required:** 3A
- Energy efficiency rating**
- Energy rating: B

- Optional accessories**
- Ducting kits:
 - 120mm, AED51/53/54
 - 150mm, AED61/63/64
 - Charcoal filter for re-circulation, CHA23 (pack of 1)

- Available in**
- Stainless steel
 - Black

- Technical specification**
- Required height over gas hob: 750mm (min)
 - Required height over electric hob: 650mm (min)

- Fitting note**
- Please ensure that you check the ceiling height is sufficient to allow the required clearance between the hob and extractor.

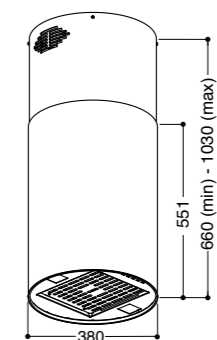



EVP61

EVP61 - 60cm wide
 EVP91 - 90cm wide
 EVP101 - 100cm wide
 EVP121 - 120cm wide

EVP91

EVP61/91/101/121 Linear extractor

- Features**
- Ducted/re-circulating installation
 - 3 speeds + intensive
 - Touch control
 - Aluminium grease filters
 - 2 x 20W halogen lights
 - Twin fan motor
 - Filter saturation warning light
 - Clean air function
 - 15 minute timer
- Extraction rate: 503m³/h**
- Rated electrical power: 290W**
- Power supply required: 3A**
- Energy efficiency rating**
- Energy rating: D
- Fitting note**
- Please ensure that you check the ceiling height is sufficient to allow the required clearance between the hob and extractor.

- Optional accessories**
- Ducting kit, AED61/63/64
 - Charcoal filter for re-circulation, CHA21 (pack of 2)

- Available in**
- Stainless steel

- Technical specification**
- Required height over gas hob: 700mm (min)
 - Required height over electric hob: 600mm (min)
 - Outlet diameter: 150mm
 - Noise level: 62dBA

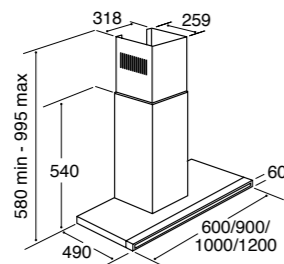

EVPK90 Linear island extractor

- Features**
- Ducted/re-circulating installation
 - 3 speeds + intensive
 - Touch control
 - Aluminium grease filters
 - 4 x 20W halogen lights
 - Twin fan motor
 - Filter saturation warning light
 - Clean air function
 - 15 minute timer
- Extraction rate: 520m³/h**
- Rated electrical power: 330W**
- Power supply required: 3A**
- Energy efficiency rating**
- Energy rating: D
- Fitting note**
- Please ensure that you check the ceiling height is sufficient to allow the required clearance between the hob and extractor.

- Optional accessories**
- Ducting kit, AED61/63/64
 - Charcoal filter for re-circulation, CHA21 (pack of 2)

- Available in**
- Stainless steel

- Technical specification**
- Required height over gas hob: 700mm (min)
 - Required height over electric hob: 600mm (min)
 - Outlet diameter: 150mm
 - Noise level: 64dBA

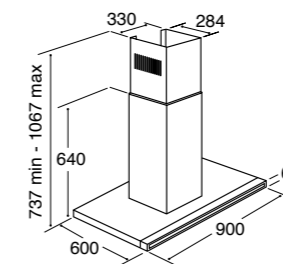

Clean air function

The clean air function means that your extractor comes on for ten minutes every hour, outside of use during cooking. In these ten minutes the extractor works to purify the air in your kitchen, meaning it is not just a companion for your hob; it even works hard when you are not cooking.



EVQ71
Circular extractor

- Features**
- Ducted/re-circulating installation
 - 3 speeds
 - Touch control
 - Aluminium grease filter
 - 2 x 2W LED lights
 - Timer function

- Optional accessories**
- Ducting kit, AED61/63/64
 - Charcoal filter for re-circulation, CHA33 (pack of 2)

- Available in**
- Stainless steel with black glass fascia

- Technical specification**
- Required height over gas hob: 700mm (min)
 - Required height over electric hob: 600mm (min)
 - Outlet diameter: 150mm
 - Noise level: 62dBA
 - Extraction rate: 579m³/h
 - Rated electrical power: 74W

- Power supply required: 3A
- Energy efficiency rating**
- Energy rating: A++
- Fitting note**
- Please ensure that you check the ceiling height is sufficient to allow the required clearance between the hob and extractor.

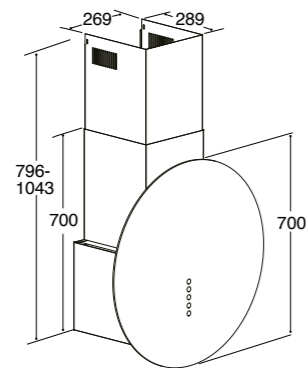

3U10
Updraft extractor

- Features**
- Ducted/re-circulating installation
 - 3 speeds + intensive
 - Touch control
 - Aluminium grease filter
 - 1 x 10W LED strip light
 - Filter saturation warning light
 - 10 minute timer

- Optional accessories**
- Ducting kit, AED61/63/64
 - Charcoal filter for re-circulation, CHA32 (pack of 2)

- Available in**
- Stainless steel with black glass fascia

- Technical specification**
- Required height over gas hob: 650mm (min)
 - Required height over electric hob: 650mm (min)
 - Outlet diameter: 150mm
 - Noise level: 68dBA
 - Extraction rate: 496m³/h

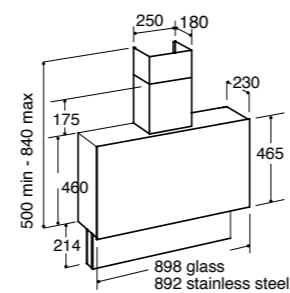

Black



White

3S10
Spherical extractor

- Features**
- Re-circulating installation
 - 3 speeds + intensive
 - Aluminium grease filter
 - 3S10BL - 1 x 3W LED downlight
 - 3S10WH - 2 x 40W neon lights
 - 10 minute timer

- Accessories**
- Remote control
 - Charcoal filter for re-circulation, CHA30 (pack of 2)

- Available in**
- White
 - Black

- Technical specification**
- Required height over gas hob: 650mm (min)
 - Required height over electric hob: 650mm (min)
 - Noise level: 48dBA
 - Extraction rate: 320m³/h

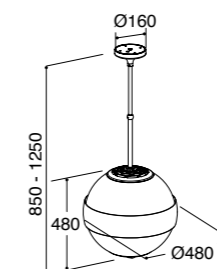

Focal point
The 3S10 in black has crisp LED downlighting to illuminate your cooking space whilst the 3S10 in white provides an ambient glow with internal neon lights.



- Rated electrical power: – 143W (3S10BL) – 220W (3S10WH)
 - Power supply required: 3A
- Fitting note**
- Please ensure that you check the ceiling height is sufficient to allow the required clearance between the hob and extractor.



EVX101 Ceiling extractor

- Features**
- Ducted/re-circulating installation
 - 8 speeds + intensive
 - Soft touch buttons
 - Stainless steel grease filters
 - 4 x 4W LED lights
 - Filter saturation warning light
 - Clean air function
 - 30 minute timer
 - Peripheral aspiration
- Accessories**
- Remote control
- Optional accessories**
- Ducting kit, AED61/63/64
 - Charcoal filter for re-circulation, CHA18 (pack of 2)

- Required height over electric hob: 750mm (min)
 - Outlet diameter: 150mm
 - Noise level: 64dBA
 - Extraction rate: 570m³/h
 - Rated electrical power: 286W
 - Power supply required: 3A
- Energy efficiency rating**
- Energy rating: B
- Fitting note**
- The extraction outlet can be rotated through 90°, 180° or 270°, allowing for flexible installation.

- Available in**
- Stainless steel
- Technical specification**
- Required height over gas hob: 750mm (min)

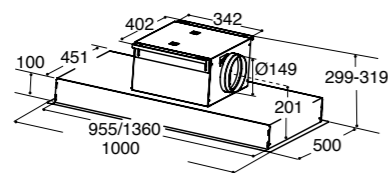

White



Stainless steel

EVX110 Ceiling extractor

- Features**
- Ducted/re-circulating installation
 - 3 speeds + intensive
 - Aluminium grease filter
 - 2 x 10.5W dimmable LED strip lights
 - Timer function
 - Peripheral aspiration
- Accessories**
- Remote control
- Optional accessories**
- Ducting kit, AED61/63/64
 - Charcoal filter for re-circulation, CHA20 (pack of 2)
- Available in**
- White glass
 - Stainless steel

- Noise level: 63dBA
 - Extraction rate: 615m³/h
 - Rated electrical power: 296W
 - Power supply required: 3A
 - Supplied with a UK plug
- Energy efficiency rating**
- Energy rating: A

Fitting note

- Please ensure that you check the ceiling height is sufficient to allow the required clearance between the hob and extractor.

- Technical specification**
- Required height over gas hob: 650mm (min)
 - Required height over electric hob: 650mm (min)
 - Outlet diameter: 150mm

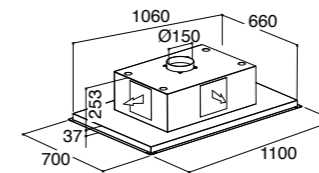



EDD61



Downdraft extractors
 Sleek and efficient, downdraft extractors slip effortlessly away below the worktop when not in use - the perfect choice for a minimalist, modern kitchen, or for a room where a low ceiling height limits the use of an overhead extractor.



EDD91

EDD61/91
 Downdraft extractor

- Features**
- Ducted/re-circulating installation
 - EDD61: 4 speeds
 - EDD91: 3 speeds + intensive
 - Touch control
 - Aluminium grease filters
 - 10 minute timer
 - Synchronised sliding system
 - Glass control panel and side panel
 - Motor included

- Noise level:
 - EDD61: 69dBA
 - EDD91: 61dBA
- Extraction rate:
 - 636m³/h (EDD61)
 - 605m³/h (EDD91)
- Rated electrical power: 200W
- Power supply required: 3A

- Energy efficiency rating**
- Energy rating:
 - EDD61: A
 - EDD91: A+

- Optional accessories**
- Ducting kit, AED61/63/64
 - Charcoal filter for re-circulation:
 - EDD61, CHA19 (pack of 2)
 - EDD91, CHA11 (pack of 2)

- Available in**
- Black

- Technical specification**
- Outlet diameter: 150mm

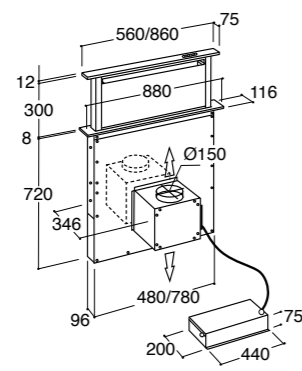

3D9
 Downdraft extractor

- Features**
- Ducted/re-circulating installation
 - 3 speeds + intensive
 - Touch control
 - Aluminium grease filters
 - 1 x 14W neon light
 - 10 minute timer
 - Synchronised sliding system
 - Glass control panel and side panel
 - Motor included

- Power supply required: 3A
- Energy efficiency rating
- Energy rating: A

Co-ordinating products
 This extractor matches any of our linear hobs.

- Optional accessories**
- Ducting kit, AED61/63/64
 - Charcoal filter for re-circulation, CHA14 (pack of 2)

- Available in**
- Black

- Technical specification**
- Outlet diameter: 150mm
 - Noise level: 61dBA
 - Extraction rate: 605m³/h
 - Rated electrical power: 289W

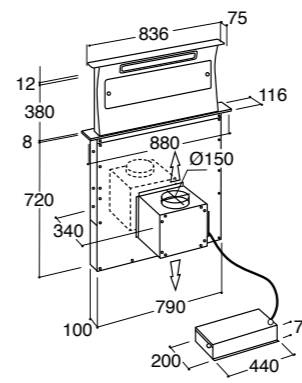

Cooling

Our refrigeration range includes everything from American style fridge freezers to under counter fridges, all carefully designed to keep your food under optimum conditions.



The ice and water dispenser on the PC71 American style fridge freezer will never run out of cubed or crushed ice for your drinks. Plumbing the dispenser straight into your water supply means that you can have chilled, filtered water on tap!

A+ energy efficiency

Our entire refrigeration range is at least A+ rated for energy efficiency. A+ rated products use up to 25% less energy than A rated models, meaning lower running costs.



4 star freezers

All CDA freezers come with a 4 star rating, the highest classification available. A 4 star rating allows you to store frozen food for up to 12 months and freeze fresh food efficiently and safely.

Multi-airflow

Introducing fresh food to your freezer can increase the temperature temporarily and new items may take longer to freeze. Using the fast freeze function will boost your freezer power to bring the fresh items down to temperature quickly and safely.

The multi-airflow design on the PC870 & PC900 has been created to improve the cool air circulation in and around food and drink in your fridge. By increasing the airflow, the fridge works more efficiently at cooling your perishables, keeping them fresher for longer.



LED interior lighting

This eye-catching feature will delight you as soon as you open the door. The LED lights emit no heat and run on very little energy. Plus, the beautifully designed PC900 American style premium frost free four door fridge freezer is bright enough to cast light into every corner of the fridge.



Draught beer dispenser

This unique compact appliance can serve a beautiful pub-style pint of beer or lager in your own kitchen! The professional beer connection kit is pre-assembled on a steel plate ready for positioning below the dispenser. The beer passes through the integral flash chiller before it is dispensed at your preferred temperature.

Quick guide to refrigeration

The CDA refrigeration range includes both integrated and freestanding options.

Integrated models offer a variety of fridge, freezer and combination options to suit your kitchen.

The freestanding range includes the superb American style side-by-sides and a range of wine coolers.

All CDA fridges have an automatic self-defrosting feature so you never have to spend time defrosting your fridge.

Integrated refrigeration



FW223
 • Under counter larder fridge
 • Energy rating: A+
 More details on p120



FW253
 • Under counter fridge with ice box
 • Energy rating: A+
 More details on p120



FW283
 • Under counter freezer
 • Energy rating: A+
 More details on p121

Integrated refrigeration



FW522
 • Three-quarter height larder fridge
 • Energy rating: A+
 More details on p124



FW582
 • Three-quarter height freezer
 • Energy rating: A+
 More details on p124



FW821
 • Full height fridge
 • Energy rating: A+
 More details on p125

Integrated refrigeration



FW951
 • 50/50 frost free fridge/freezer
 • Energy rating: A+
 More details on p128



FW971
 • 70/30 frost free fridge/freezer
 • Energy rating: A+
 More details on p128

Freestanding refrigeration



PC880
 • American style four door fridge freezer
 • Energy rating: A+
 More details on p133



PC870
 • American style two door fridge with two drawer freezer
 • Energy rating: A+
 More details on p134



PC900
 • American style premium four door fridge freezer
 • Energy rating: A+
 More details on p135

Integrated refrigeration



FW321
 • Under counter larder fridge
 • Energy rating: A+
 More details on p121



FW381
 • Under counter freezer
 • Energy rating: A+
 More details on p122



FW422
 • In-column larder fridge
 • Energy rating: A+
 More details on p122



FW482
 • In-column freezer
 • Energy rating: A+
 More details on p123

Integrated refrigeration



FW881
 • Full height freezer
 • Energy rating: A+
 More details on p125



FW852
 • 50/50 fridge/freezer
 • Energy rating: A+
 More details on p126



FW872
 • 70/30 fridge/freezer
 • Energy rating: A+
 More details on p126



FW925
 • 50/50 fridge/freezer
 • Energy rating: A+
 More details on p127



FW927
 • 70/30 fridge/freezer
 • Energy rating: A+
 More details on p127

Freestanding refrigeration



FF880
 • Full height freezer
 • Energy rating: A++
 More details on p129



FF820
 • Full height larder fridge
 • Energy rating: A++
 More details on p129



PC52
 • American style side-by-side fridge freezer
 • Energy rating: A+
 More details on p130



PC71
 • American style side-by-side fridge freezer
 • Energy rating: A+
 More details on p131



PC84
 • American style two door fridge with two drawer freezer
 • Energy rating: A+
 More details on p132

Wine coolers



Freestanding and integrated
 See p136-137

Beer dispenser



BVB4
 • Professional fully integrated beer dispenser
 More details on p144



FW223
Integrated/under counter larger fridge



- Features
- Interior light
 - 3 glass shelves
 - 1 salad crisper compartment
 - 2 in-door balconies
 - 1 egg tray
- Technical specification
- Height adjustable feet
 - Reversible door
 - Fixed hinges
 - Total useable capacity: 133L net
 - Noise level: 39dBA
- Energy efficiency rating
- Energy rating: A+
- Energy consumption
- Energy consumption per annum: 115kW.h

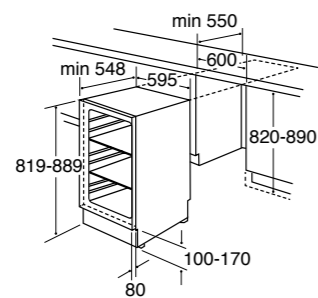

FW253
Integrated/under counter fridge with ice box



- Features
- Interior light
 - 2 glass shelves
 - 1 salad crisper compartment
 - 2 in-door balconies
 - 1 egg tray
- Ice box features
- 4 star rating
 - 1 ice cube tray
- Technical specification
- Front adjustable feet
 - Reversible door
 - Fixed hinges
 - Fridge useable capacity: 98L net
 - Ice box useable capacity: 17L net
 - Total useable capacity: 115L net
 - Freezing capacity: 2kg/24h
 - Noise level: 39dBA
- Energy efficiency rating
- Energy rating: A+
- Energy consumption
- Energy consumption per annum: 171kW.h

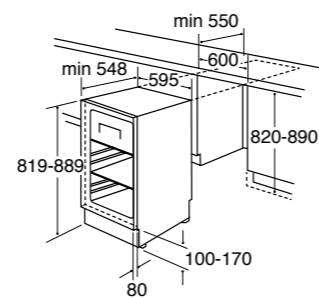

FW283
Integrated/under counter freezer



- Features
- 4 star rating
 - 3 storage compartments
 - 1 ice cube tray
- Technical specification
- Height adjustable feet
 - Reversible door
 - Fixed hinges
 - Total useable capacity: 93L net
 - Freezing capacity: 9kg/24h
 - Noise level: 44dBA
- Energy efficiency rating
- Energy rating: A+
- Energy consumption
- Energy consumption per annum: 177kW.h

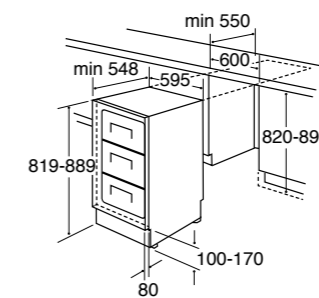

FW321
Integrated/under counter larger fridge



- Features
- Interior light
 - 3 stainless steel edged glass shelves
 - 1 salad crisper compartment
 - 2 in-door balconies
 - 1 egg tray
- Technical specification
- Height adjustable feet
 - Reversible door
 - Fixed hinges
 - Total useable capacity: 133L net
 - Noise level: 39dBA
- Energy efficiency rating
- Energy rating: A+
- Energy consumption
- Energy consumption per annum: 115kW.h

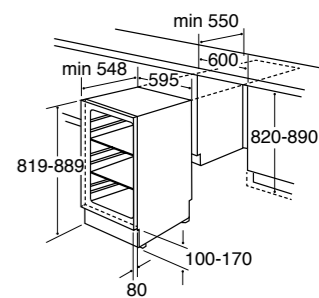



FW381
Integrated/under counter freezer



Features

- 4 star rating
- 3 storage compartments
- 1 ice cube tray

Technical specification

- Height adjustable feet
- Reversible door
- Fixed hinges
- Total useable capacity: 93L net
- Freezing capacity: 9kg/24h
- Noise level: 44dBA

Energy efficiency rating

- Energy rating: A+

Energy consumption

- Energy consumption per annum: 177kW.h

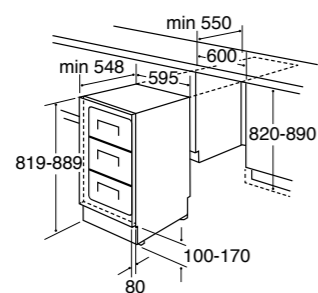

FW422
Integrated in-column larder fridge



Features

- Interior light
- 4 glass shelves
- 2 salad crisper drawers
- 3 in-door balconies
- 1 egg tray

Technical specification

- Reversible door
- Fixed hinges
- Total useable capacity: 134L net
- Noise level: 41dBA

Energy efficiency rating

- Energy rating: A+

Energy consumption

- Energy consumption per annum: 121kW.h

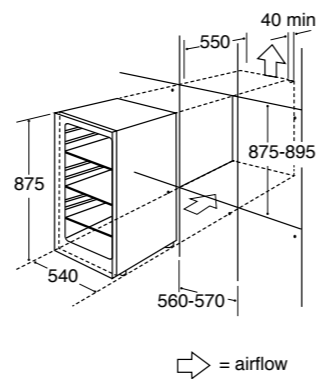

FW482
Integrated in-column freezer



Features

- 4 star rating
- 4 storage compartments
- 1 ice cube tray

Technical specification

- Reversible door
- Fixed hinges
- Total useable capacity: 99L net
- Freezing capacity: 8kg/24h
- Noise level: 39dBA

Energy efficiency rating

- Energy rating: A+

Energy consumption

- Energy consumption per annum: 195kW.h

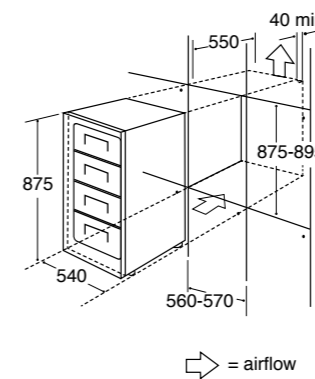



FW522
Integrated three-quarter height larder fridge



- Features
- LED interior light
 - 4 glass shelves
 - 1 salad crisper drawer
 - 3 in-door balconies
 - 1 egg tray

- Technical specification
- Height adjustable feet
 - Reversible door
 - Fixed hinges
 - Total useable capacity: 197L net
 - Noise level: 41dBA

- Energy efficiency rating
- Energy rating: A+

- Energy consumption
- Energy consumption per annum: 128kW.h

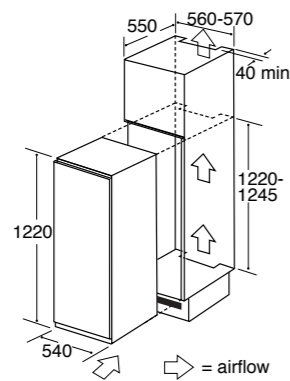

FW582
Integrated three-quarter height freezer



- Features
- 4 star rating
 - 5 storage compartments
 - 1 ice cube tray
 - Fast freeze
 - Temperature warning light

- Technical specification
- Height adjustable feet
 - Reversible door
 - Fixed hinges
 - Total useable capacity: 130L net
 - Freezing capacity: 6.5kg/24h
 - Noise level: 41dBA

- Energy efficiency rating
- Energy rating: A+

- Energy consumption
- Energy consumption per annum: 215kW.h

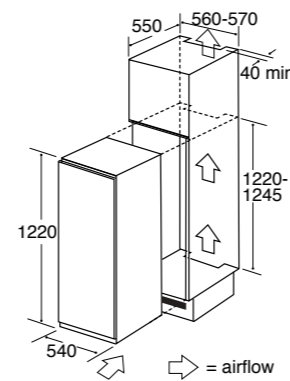

FW821
Integrated full height larder fridge



- Features
- LED interior lighting
 - 6 glass shelves
 - 2 salad crisper drawers
 - 5 in-door balconies
 - 1 egg tray

- Technical specification
- Front adjustable feet
 - Reversible door
 - Sliding furniture fixings
 - Total useable capacity: 298L net
 - Noise level: 39dBA

- Energy efficiency rating
- Energy rating: A+

- Energy consumption
- Energy consumption per annum: 141kW.h

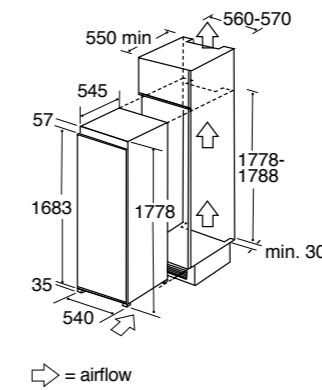

FW881
Integrated full height freezer



- Features
- 4 star rating
 - Temperature warning light
 - Fast freeze
 - 9 storage compartments
 - 1 ice cube tray

- Technical specification
- Front adjustable feet
 - Reversible door
 - Sliding furniture fixings
 - Total useable capacity: 198L net
 - Freezing capacity: 10.5kg/24h
 - Noise level: 39dBA

- Energy efficiency rating
- Energy rating: A+

- Energy consumption
- Energy consumption per annum: 258kW.h

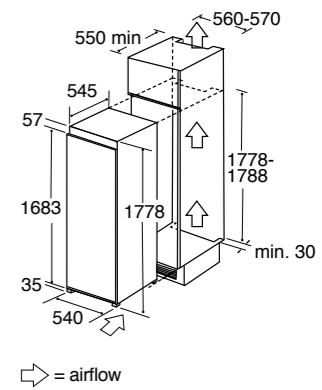



FW852
Integrated 50/50 combination fridge freezer



- Fridge features**
- LED interior lighting
 - Electronic control
 - 3 glass shelves
 - 2 salad crisper drawers
 - 3 in-door balconies
 - 1 egg tray
 - Chrome bottle rack

- Freezer features**
- 4 star rating
 - Fast freeze
 - 4 storage compartments
 - 1 ice cube tray

- Technical specification**
- Reversible doors
 - Sliding furniture fixings
 - Fridge useable capacity: 147L net
 - Freezer useable capacity: 81L net
 - Total useable capacity: 228L net
 - Freezing capacity: 4.5kg/24h
 - Noise level: 39dBA

- Energy efficiency rating**
- Energy rating: A+

- Energy consumption**
- Energy consumption per annum: 263kW.h

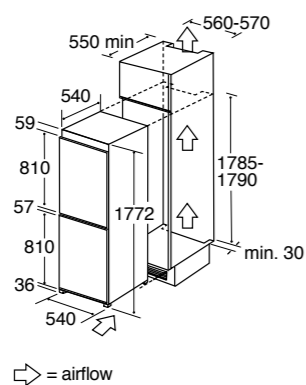

FW872
Integrated 70/30 combination fridge freezer



- Fridge features**
- LED interior lighting
 - Electronic control
 - 4 glass shelves
 - 2 salad crisper drawers
 - 4 in-door balconies
 - 1 egg tray
 - Chrome bottle rack

- Freezer features**
- 4 star rating
 - Fast freeze
 - 3 storage compartments
 - 1 ice cube tray

- Technical specification**
- Reversible doors
 - Sliding furniture fixings
 - Fridge useable capacity: 182L net
 - Freezer useable capacity: 60L net
 - Total useable capacity: 242L net
 - Freezing capacity: 3.5kg/24h
 - Noise level: 39dBA

- Energy efficiency rating**
- Energy rating: A+

- Energy consumption**
- Energy consumption per annum: 260kW.h

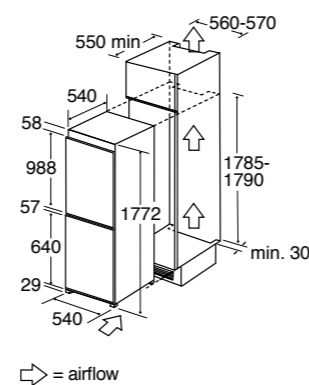

FW925
Integrated 50/50 combination frost free fridge freezer



- Fridge features**
- LED interior lighting
 - Electronic control
 - 4 glass shelves
 - 2 salad crisper drawers
 - 3 in-door balconies
 - 1 egg tray
 - Chrome bottle rack

- Freezer features**
- 4 star rating
 - Frost free
 - 4 storage compartments
 - 1 ice cube tray

- Technical specification**
- Reversible doors
 - Sliding furniture fixings
 - Fridge useable capacity: 158L net
 - Freezer useable capacity: 77L net
 - Total useable capacity: 235L net
 - Freezing capacity: 4.5kg/24h
 - Noise level: 41dBA

- Energy efficiency rating**
- Energy rating: A+

- Energy consumption**
- Energy consumption per annum: 280kW.h

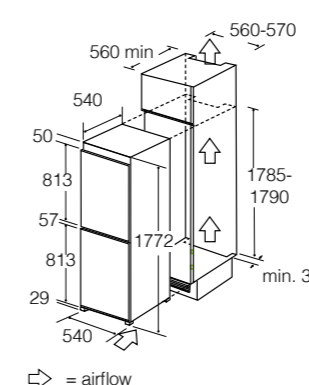

FW927
Integrated 70/30 combination frost free fridge freezer



- Fridge features**
- LED interior lighting
 - Electronic control
 - 5 glass shelves
 - 1 salad crisper drawers
 - 3 in-door balconies
 - 1 egg tray
 - Chrome bottle rack

- Freezer features**
- 4 star rating
 - Frost free
 - 3 storage compartments
 - 1 ice cube tray

- Technical specification**
- Reversible doors
 - Sliding furniture fixings
 - Fridge useable capacity: 190L net
 - Freezer useable capacity: 56L net
 - Total useable capacity: 246L net
 - Freezing capacity: 3.0kg/24h
 - Noise level: 41dBA

- Energy efficiency rating**
- Energy rating: A+

- Energy consumption**
- Energy consumption per annum: 270kW.h

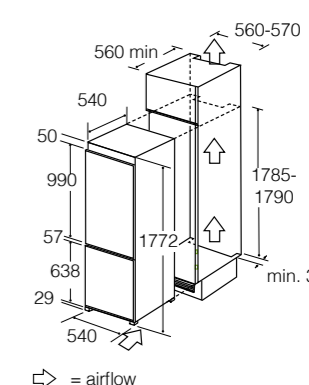



FW951
Integrated 50/50 combination frost free fridge freezer



- Fridge features**
- Multi airflow cooling system
 - LED interior lighting
 - Super cool function
 - Door open alarm
 - Electronic control
 - 4 glass shelves
 - 1 variable humidity salad crisper drawer
 - 3 in-door balconies
 - 2 egg trays
- Freezer features**
- 4 star rating
 - Frost free
 - Fast freeze
 - 4 storage compartments
 - 1 ice cube tray
- Technical specification**
- Reversible doors
 - Fixed hinges
 - Fridge useable capacity: 148L net
 - Freezer useable capacity: 84L net
 - Total useable capacity: 232L net
 - Freezing capacity: 10kg/24h
 - Noise level: 39dBA

- Energy efficiency rating**
- Energy rating: A+
- Energy consumption**
- Energy consumption per annum: 312kW.h

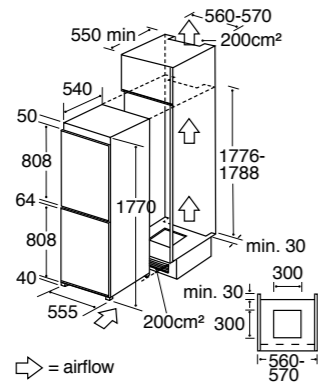

FW971
Integrated 70/30 combination frost free fridge freezer



- Features**
- Fridge features**
- Multi airflow cooling system
 - LED interior lighting
 - Super cool function
 - Door open alarm
 - Electronic control
 - 5 glass shelves
 - 1 variable humidity salad crisper drawer
 - 3 in-door balconies
 - 2 egg trays
- Freezer features**
- 4 star rating
 - Frost free
 - Fast freeze
 - 3 storage compartments
 - 1 ice cube tray
- Technical specification**
- Reversible doors
 - Fixed hinges
 - Fridge useable capacity: 179L net
 - Freezer useable capacity: 62L net
 - Total useable capacity: 241L net
 - Freezing capacity: 10kg/24h
 - Noise level: 39dBA

- Energy efficiency rating**
- Energy rating: A+
- Energy consumption**
- Energy consumption per annum: 300kW.h

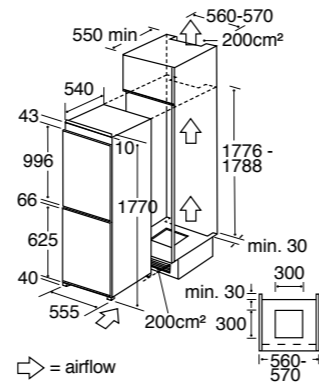

FF880
Freestanding full height frost free freezer



- Features**
- Electronic control with LED display
 - Door open signal
 - Temperature rise signal
 - 4 star rating
 - Fast freeze
 - 7 storage compartments
 - 2 in-door storage racks
 - Ice cube compartment with twist ice cube maker
 - Frost free

- Available in**
- Stainless steel effect

- Technical specification**
- Front adjustable feet
 - Reversible door
 - Total useable capacity: 260L net
 - Freezing capacity: 16kg/24h
 - Noise level: 45dBA

- Energy efficiency rating**
- Energy rating: A++

- Energy consumption**
- Energy consumption per annum: 244kW.h

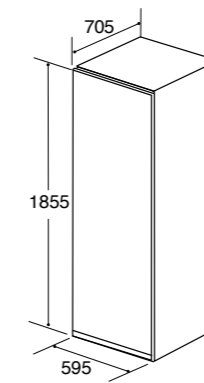

FF820 and FF880 joined configuration



FF820
Freestanding full height larder fridge



- Features**
- Electronic control with LED display
 - Door open signal
 - Temperature rise signal
 - LED interior lighting
 - 6 adjustable glass shelves
 - 2 salad crispers
 - 4 in-door balconies
 - 1 lidded dairy compartment
 - 2 storage containers

- Available in**
- Stainless steel effect

- Technical specification**
- Front adjustable feet
 - Reversible door
 - Total useable capacity: 350L net
 - Noise level: 43dBA

- Energy efficiency rating**
- Energy rating: A++

- Energy consumption**
- Energy consumption per annum: 107kW.h



FF820, FWC860 and FF880 joined configuration

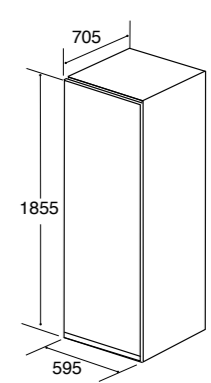



Stainless steel effect



Black

PC52
American style side-by-side frost free fridge freezer



- Features**
- Electronic control with LED display
 - Door open signal
 - Holiday mode
 - Temperature rise signal
 - Standby function
 - Energy saving mode
- Fridge useable capacity: 341L net
 - Freezer useable capacity: 177L net
 - Total useable capacity: 518L net
 - Freezing capacity: 12kg/24h
 - Noise level: 43dBA

- Fridge features**
- LED interior lighting
 - Super cooling
 - 5 adjustable glass shelves
 - 2 salad crisper drawers
 - 3 in-door balconies
 - 1 egg tray

- Freezer features**
- 4 star rating
 - Fast freeze
 - 2 storage compartments
 - 5 adjustable glass shelves
 - 4 in-door storage racks
 - Ice cube compartment with twist ice cube maker

- Available in**
- Stainless steel effect
 - Black

- Technical specification**
- Front adjustable feet
 - Total no frost

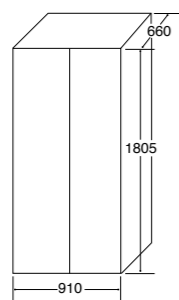

Stainless steel effect



Black

PC71
American style side-by-side frost free fridge freezer with home bar



- Features**
- Electronic control with LED display
 - Automatic ice dispenser
 - Chilled water dispenser
 - Door open signal
 - Standby function
 - Safety key lock
 - Holiday mode
- Fridge useable capacity: 375L net
 - Freezer useable capacity: 175L net
 - Total useable capacity: 550L net
 - Freezing capacity: 10kg/24h
 - Noise level: 42dBA

- Fridge features**
- LED interior lighting
 - Super cooling
 - 4 adjustable glass shelves
 - 2 salad crispers
 - 4 in-door balconies
 - Home bar

- Freezer features**
- 4 star rating
 - Fast freeze
 - 2 storage compartments
 - 3 adjustable glass shelves
 - 2 in-door storage racks
 - Ice cube compartment

- Available in**
- Stainless steel effect
 - Black

- Technical specification**
- Front adjustable feet
 - Total no frost

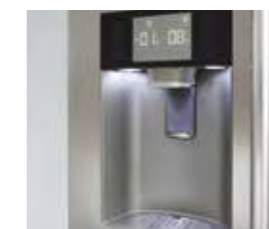
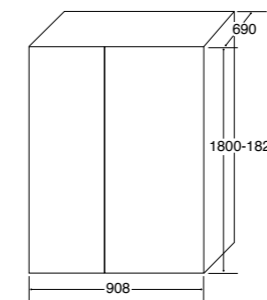

Automatic ice and water dispenser





PC84
American style two door fridge with frost free two drawer freezer



- Features**
- Electronic control with LCD display
 - Door open signal
- Fridge features**
- LED interior lighting
 - 3 adjustable glass shelves
 - 2 humidity controlled salad crisper drawers
 - 7 in-door balconies
 - 1 lidded dairy compartment
 - Meat drawer
- Freezer features**
- 4 star rating
 - Fast freeze
- Available in**
- Stainless steel effect

- Technical specification**
- Front adjustable feet
 - Total no frost
 - Fridge useable capacity: 255L net
 - Freezer useable capacity: 95L
 - Total useable capacity: 350L net
 - Freezing capacity: 10kg/24h
 - Noise level: 45dBA

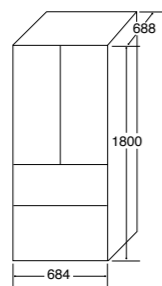

PC880
American style frost free four door fridge freezer



- Features**
- Electronic touch control with LED display
 - Door open signal
 - Holiday mode
 - PureFresh
- Fridge features**
- LED interior lighting
 - 3 adjustable glass shelves
 - 1 salad crisper
 - 4 in-door balconies
 - 2 lidded dairy compartments
- Freezer features**
- 4 star rating
 - Frost free
 - Fast freeze
 - 6 storage compartments
 - 1 ice cube tray
- Available in**
- Stainless steel effect
 - Black

- Technical specification**
- Front adjustable feet
 - Fridge useable capacity: 274L net
 - Freezer useable capacity: 144L net
 - Total useable capacity: 418L net

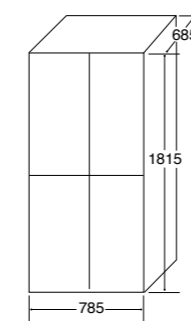

Stainless steel effect

Black



Stainless steel



Black

PC870
American style two door fridge with frost free two drawer freezer



- Features**
- Electronic touch control with LED display
 - Door open signal
 - Holiday mode
 - Temperature rise signal
 - Standby function
 - Energy saving mode
 - Safety key lock
 - Q drink

- Fridge features**
- LED interior lighting
 - Super cooling
 - 3 adjustable glass shelves
 - 2 humidity controlled fruit/veg compartments
 - 6 in-door balconies
 - 2 lidded dairy compartments
 - Soft close fresh zone drawer
 - 1 egg tray

- Freezer features**
- 4 star rating
 - Fast freeze
 - 2 storage compartments
 - 2 ice cube trays

- Available in**
- Stainless steel
 - Black

- Technical specification**
- Height adjustable feet
 - Total no frost
 - Fridge useable capacity: 362L net
 - Freezer useable capacity: 167L net
 - Total useable capacity: 529L net
 - Freezing capacity: 20kg/24h
 - Noise level: 45dBA

- Energy efficiency rating**
- Energy rating: A+

- Energy consumption**
- Energy consumption per annum: 461kW.h

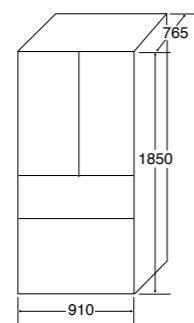

LED interior lighting

Q drink
Q drink allows you to set a handy timer and chill bottles quickly in the freezer.



Stainless steel



Black

PC900
American style premium frost free four door fridge freezer



- Features**
- Electronic touch control with LED display
 - Door open signal
 - Holiday mode
 - Temperature rise signal
 - Standby function
 - Energy saving mode
 - Safety key lock
 - Q drink
 - Flexi-cool zone

- Fridge features**
- LED interior lighting
 - Super cooling
 - 3 adjustable glass shelves
 - 2 humidity controlled fruit/veg compartments
 - 6 in-door balconies
 - 2 lidded dairy compartments
 - Soft close fresh zone drawer
 - 1 egg tray

- Freezer features**
- 4 star rating
 - Fast freeze
 - 4 storage compartments
 - 2 shelves
 - 2 ice cube trays

- Available in**
- Stainless steel
 - Black

- Technical specification**
- Height adjustable feet
 - Total no frost
 - Fridge useable capacity: 362L net
 - Freezer useable capacity: 164L net
 - Total useable capacity: 526L net
 - Freezing capacity: 13kg/24h
 - Noise level: 46dBA

- Energy efficiency rating**
- Energy rating: A+

- Energy consumption**
- Energy consumption per annum: 459kW.h

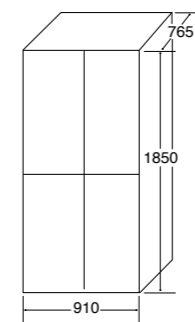

LED interior lighting

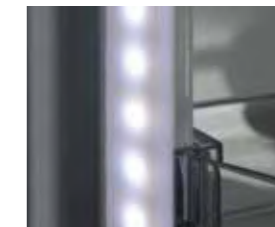

LED strip lighting

Flexi-cool zone
The flexi-cool zone is a specialised compartment which allows you to choose between fridge or freezer space, according to your food storage requirements.

Wine coolers

Using the latest anti-vibration technology, UV-protection and temperature control, CDA wine coolers keep your collection in optimum condition.

Variations in temperature, light and movement can all accelerate the ageing process and damage your collection. Installing a wine cooler is a practical and stylish addition to your kitchen. All models come with the latest technology to provide the perfect storage solution. As part of our continued commitment to safety, we have now introduced metal backing to our wine cooler range.

UV-protective toughened smoked glass doors

All CDA wine coolers have UV-protective, toughened, smoked glass doors to prevent sunlight spoiling the wine. This also assists thermal efficiency.



Luxury wooden shelving

All models feature luxury solid wooden shelves as standard (excludes 15cm slimline models). The FWV902 integrated model also has the addition of a luxury wooden display shelf (shown above).

Wine cooler glass shelf optional accessory

Our wine cooler glass shelf is perfect for storing smaller items such as bottles and cans - compatible with the FWC304, FWC604, FWC624 and FWC861 models. Please see our accessory section for details.



Digital temperature control

All CDA wine coolers are designed with electronic temperature control which is adjustable between 5°C and 20°C. The red digital display is easy to use and has a convenient memory function.

A rated energy efficiency

As we continually move forward and improve our products in response to new technology, our latest range of wine coolers has improved efficiency ratings to save on energy usage in your home.



Bright LED interior lighting

Bright LED interior lighting illuminates the internal cavity beautifully and makes finding the right bottle quick and easy.



Stainless steel Black

FWC153
Freestanding/under counter slimline wine cooler

- Features**
- Black plinth
 - Red digital display
 - Single temperature storage zone
 - 6 integrated supports
 - Electronic temperature control
 - UV-protective toughened smoked glass door
 - Double glazed door
 - LED interior lighting
 - Temperature memory function
 - Over temperature alarm
 - Height adjustable plinth section
 - Door open alarm
- Available in**
- Stainless steel
 - Black glass

- Energy efficiency rating**
- Energy rating: B
- Energy consumption**
- Energy consumption per annum: 185kW.h

- Technical specification**
- Reversible door
 - Rated electrical power: 60W
 - Power supply required: 13A
 - Noise level: 40dBA
 - Temperature range: 5°C to 20°C
 - Total bottle storage: 7 (75cL Bordeaux bottles)
 - Compressor driven

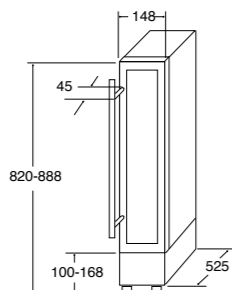

Stainless steel Black

FWC304
Freestanding/under counter slimline wine cooler



- Features**
- Black plinth
 - Red digital display
 - Single temperature storage zone
 - 5 wooden slide-out shelves
 - Electronic temperature control
 - UV-protective toughened smoked glass door
 - Double glazed door
 - LED interior lighting
 - Temperature memory function
 - Over temperature alarm
 - Height adjustable plinth section
 - Humidifier to maintain 50-80% RH
 - Door open alarm

- Optional accessories**
- Glass shelves (pack of 3), AFG31

- Available in**
- Stainless steel
 - Black glass

- Technical specification**
- Reversible door
 - Rated electrical power: 85W
 - Power supply required: 13A
 - Noise level: 39dBA

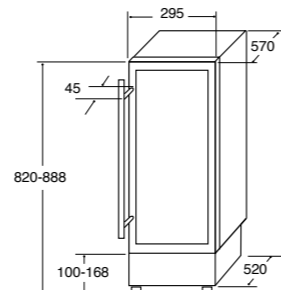

Stainless steel Black

FWC604
Freestanding/under counter wine cooler

- Features**
- Black plinth
 - Red digital display
 - Dual temperature storage zones
 - 5 wooden slide-out shelves
 - Electronic temperature control
 - UV-protective toughened smoked glass door
 - Double glazed door
 - LED interior lighting
 - Temperature memory function
 - Over temperature alarm
 - Height adjustable plinth section
 - Integral heater
 - Humidifier to maintain 50-80% RH
 - Door open alarm

- Optional accessories**
- Glass shelves (pack of 3), AFG61

- Available in**
- Stainless steel
 - Black glass

- Technical specification**
- Reversible door
 - Rated electrical power: 100W
 - Power supply required: 13A

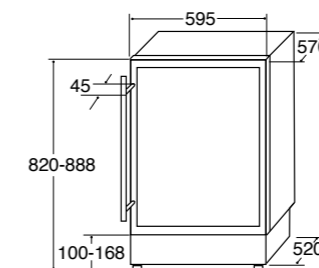

Stainless steel Black

FWC624
Freestanding/under counter double door wine cooler

- Features**
- Black plinth
 - Red digital display
 - Dual temperature storage zones
 - 11 wooden slide-out shelves
 - Electronic temperature control
 - UV-protective toughened smoked glass door
 - Triple glazed door
 - LED interior lighting
 - Temperature memory function
 - Over temperature alarm
 - Height adjustable plinth section
 - 2 humidifiers to maintain 50-80% RH
 - Door open alarm

- Optional accessories**
- Glass shelves (pack of 3), AFG31

- Available in**
- Stainless steel
 - Black glass

- Technical specification**
- Rated electrical power: 100W
 - Power supply required: 13A
 - Noise level: 40dBA

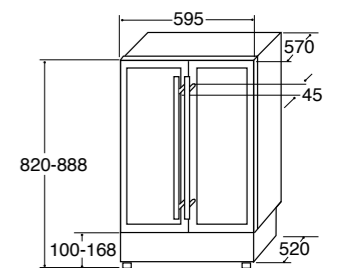

- Temperature range in left zone: 5°C to 20°C
- Temperature range in right zone: 5°C to 20°C
- Bottle storage in left zone: 20 (75cL Bordeaux bottles)
- Bottle storage in right zone: 20 (75cL Bordeaux bottles)
- Total bottle storage: 40 (75cL Bordeaux bottles)
- Compressor driven

- Energy efficiency rating**
- Energy rating: B

- Energy consumption**
- Energy consumption per annum: 190kW.h



Top tip
 Co-ordinate the FF820, FWC861 and FF880 for the ultimate cooling station. Remember to add an AFJ61 kit containing the joining strips and plinth to seamlessly combine all three appliances.

FWC861
 Full height freestanding wine cooler

- Features**
- Black plinth
 - Red digital display
 - Dual temperature storage zones
 - 14 wooden slide-out shelves
 - Electronic temperature control
 - UV-protective toughened smoked glass door
 - Triple glazed door
 - LED interior lighting
 - Energy saving mode
 - Temperature memory function
 - Over temperature alarm
 - Door open alarm
 - Humidifier in upper zone to maintain 50-80% RH
 - Integral heater
- Noise level: 43dBA
- Temperature range in upper zone: 5°C to 20°C
- Temperature range in lower zone: 5°C to 20°C
- Bottle storage in upper zone: 63 (75cL Bordeaux bottles)
- Bottle storage in lower zone: 62 (75cL Bordeaux bottles)
- Total bottle storage: 125 (75cL Bordeaux bottles)
- Compressor driven
- Energy efficiency rating**
- Energy rating: B
- Energy consumption**
- Energy consumption per annum: 225kW.h

- Optional accessories**
- Glass shelves (pack of 3), AFG61
 - Joining kit, AFJ61

- Available in**
- Black

- Technical specification**
- Height adjustable feet
 - Reversible door
 - Rated electrical power: 160W
 - Power supply required: 13A

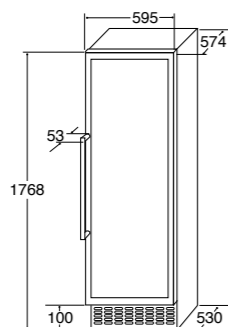

Co-ordinate the FF820, FWC861 and FF880 for the ultimate cooling station. Remember to add an AFJ61 kit containing the joining strips and plinth to seamlessly combine all three appliances.



FWV902
 Integrated wine cooler

- Features**
- Red digital display
 - Dual temperature storage zones
 - 5 wooden slide-out shelves and 1 wooden display shelf
 - Electronic temperature control
 - UV-protective toughened smoked glass door
 - Triple glazed door
 - LED interior lighting
 - Temperature memory function
 - Over temperature alarm
 - Door open alarm
 - Energy saving mode
 - Display light function
 - Humidifier to maintain 50-80% RH
- Temperature range in lower zone: 5°C to 20°C
- Bottle storage in upper zone: 22 (75cL Bordeaux bottles)
- Bottle storage in lower zone: 35 (75cL Bordeaux bottles) 30 when using display shelf
- Total bottle storage: 57 or 52 when using display shelf (75cL Bordeaux bottles)
- Compressor driven
- Energy efficiency rating**
- Energy rating: B
- Energy consumption**
- Energy consumption per annum: 195kW.h

- Accessories**
- 1 wooden display shelf

- Available in**
- Black

- Technical specification**
- Reversible door
 - Rated electrical power: 100W
 - Power supply required: 13A
 - Noise level: 40dBA
 - Temperature range in upper zone: 5°C to 20°C

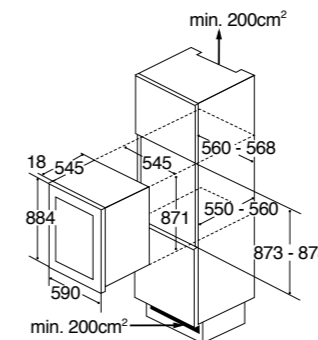



FWV452
Integrated compact wine cooler



Features

- Red digital display
- Single temperature storage zone
- 3 wooden slide-out shelves
- Electronic temperature control
- UV-protective toughened smoked glass door
- Triple glazed door
- LED interior lighting
- Temperature memory function
- Over temperature alarm
- Door open alarm
- Energy saving mode
- Display light function
- Humidifier to maintain 50-80% RH

Energy efficiency rating

- Energy rating: A

Energy consumption

- Energy consumption per annum: 140kW.h

Available in

- Black

Technical specification

- Reversible door
- Rated electrical power: 85W
- Power supply required: 13A
- Noise level: 39dBA
- Temperature range: 5°C to 20°C
- Bottle storage: 24 (75cL Bordeaux bottles)
- Compressor driven

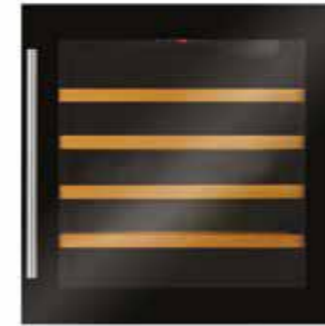
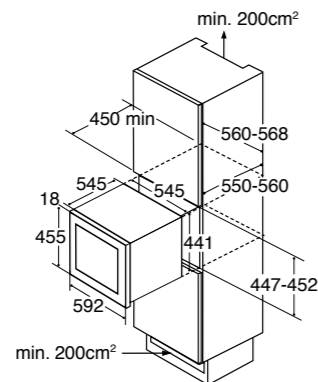

FWV601
Integrated compact wine cooler



Features

- Red digital display
- Single temperature storage zone
- 4 wooden slide-out shelves
- Electronic temperature control
- UV-protective toughened smoked glass door
- Triple glazed door
- LED interior lighting
- Temperature memory function
- Over temperature alarm
- Door open alarm
- Energy saving mode
- Display light function
- Humidifier to maintain 50-80% RH

Energy efficiency rating

- Energy rating: A

Energy consumption

- Energy consumption per annum: 140kW.h

Available in

- Black

Technical specification

- Reversible door
- Rated electrical power: 100W
- Power supply required: 13A
- Noise level: 39dBA
- Temperature range: 5°C to 20°C
- Bottle storage: 40 (75cL Bordeaux bottles)
- Compressor driven

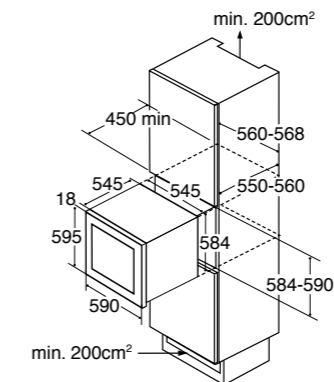

Integrated compact draught beer dispenser

With an integrated flash chiller, this beer dispenser will have your drink chilled and ready to serve in just 5 minutes.



BVB4 Integrated compact draught beer dispenser

Features

- Professional fully integrated beer dispenser
- Compatible with 10L, 30L and 50L kegs
- Ready to dispense beer within five minutes of installation without chilling the keg in advance
- Supplied with CO₂ canister
- Temperature controlled by thermostat: 4°C to 8°C
- LED lighting
- Easy cleaning process
- Removable drip tray
- Supplied with S-type connector

Optional accessories

- Alternative keg connectors, ABC001 (G-type)/ABC005(A-type)
- CO₂ bottle, ABC002
- Cleaning tablets, ABC003
- Alternative cleaning connectors, ABC004/ABC006

Available in

- Stainless steel

Technical specification

- Rated electrical power: 190W
- Power supply required: 13A

- Draught capacity:
 - 40L/h Δt 10k
 - 14.5L/h Δt 20k
- Cooling capacity: 465W/400kcal/h



This appliance is supplied with a full professional connecting kit and is designed to fit in a full height unit, which will house the beer keg and connections directly below the built-in dispensing unit.

The line drawing shows the dimensions of the built-in dispensing unit only.

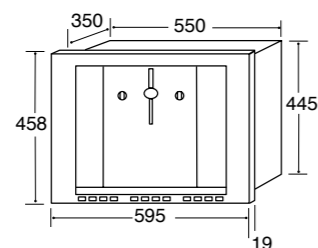

Dishwashers

CDA dishwashers have been designed with function and performance in mind. Combining energy saving features and intelligent technology they deliver perfect results, every time.



Our intelligent dishwashers sense the level of soiling and select the corresponding temperature and amount of water for the best possible wash performance. Energy and water usage is optimised by using only the energy required for the job and no more.

Drying

Special features like Active Drying, on models like the WC600, mean that your dishwasher doesn't rely on passive heat to dry the dishes. Instead, it forces air around the cavity using a fan; drying them quickly and efficiently.



Energy efficiency

Our dishwasher models have all been rated A++ for energy efficiency, ensuring that they use the least amount of water possible to give brilliant wash results while also using the smallest amount of energy possible.



Flood protection

All our dishwashers offer leak detection to avoid flood damage in your home. For total peace of mind, the Aquastop system in models like the WC600 dishwasher will automatically cut off the water supply in the event of a leak or flood.



Water consumption

It is a common misconception that dishwashers use more water than hand washing alone. The average household would complete two lots of hand washing per day, using 21 litres of water each time. With CDA dishwashers using between just 9 and 12 litres of water per load, and holding up to 15 place settings, you can take care of the washing up, your energy usage and water consumption all at the same time, whilst being friendly to the environment.

Quick guide to dishwashers

CDA dishwashers combine state-of-the-art technology with meticulous build quality to give you reliable performance for years to come.

All our dishwashers feature:

- A++ rating for energy efficiency
- Cold water fill
- Counter-balanced door
- Upper height-adjustable basket to accommodate larger items
- Concealed heating element to protect the bottom basket
- Delay timer to take advantage of off-peak electricity

Slimline integrated dishwashers



WC432

- 10 place settings
 - 6 programmes
 - Delay timer
 - Energy rating: A++
- More details on p150

WC480

- 10 place settings
 - 8 programmes
 - Delay timer
 - Top level cutlery basket
 - Half load
 - Energy rating: A++
- More details on p151

Integrated dishwashers



WC142

- 13 place settings
 - 5 programmes
 - Delay timer
 - Energy rating: A++
- More details on p152



WC371

- 13 place settings
 - 9 programmes
 - Delay timer
 - Half load
 - Energy rating: A++
- More details on p152

WC600

- 15 place settings
 - 9 programmes
 - Delay timer
 - Half load
 - Top level cutlery basket
 - Energy rating: A++
- More details on p153



WC432
Integrated slimline dishwasher



Features

- 10 place settings
- Half load
- 3/6/9 hour delay timer
- 3 spray levels
- LED rinse aid indicator
- LED salt indicator
- LED progress indicator
- Acoustic signal for end of programme
- Electronic softener adjustment
- Height adjustable upper basket
- Overflow protection
- Levelling feet with front control
- Grey baskets

Programmes

- 6 programmes
 - Prewash (cold)
 - Quick wash 40°C
 - Eco 50°C
 - Express 65°C
 - Intensive 65°C
 - Intensive+ 70°C

Technical specification

- Rated electrical power: 1.9kW
- Power supply required: 13A
- Noise level: 49dBA

Energy efficiency rating

- Energy rating: A++
- Wash rating: A
- Drying rating: A

Energy consumption

- Energy consumption per annum: 211kW.h
- Water consumption per annum: 3080L
- Energy consumption per cycle: 0.73kW.h
- Water consumption per cycle: 11L

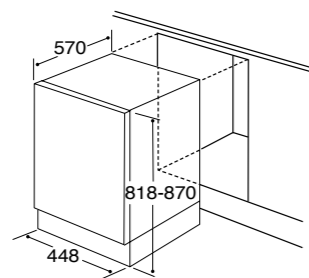

Top level cutlery drawer.

WC480
Integrated intelligent slimline dishwasher



Features

- 10 place settings
- Half load operates either upper or lower baskets individually or half load of both baskets
- 1-19 hour delay timer
- 3 spray levels
- LED rinse aid indicator
- LED salt indicator
- Acoustic signal for end of programme
- Electronic softener adjustment
- 3-in-1 function
- Levelling feet with front control
- Height adjustable upper basket when loaded
- Overflow protection
- Top level cutlery drawer
- GlassGuard - wine glass supports
- Grey baskets

Programmes

- 8 programmes
 - Prewash (cold)
 - Quick wash 40°C
 - Eco 50°C
 - 50 minute express wash 65°C
 - Auto normal 50-60°C
 - Auto intensive 60-70°C
 - Auto delicate 30-50°C
 - Intensive+ 70°C

Optional accessories

- Variospace wine glass holder, AWG100

Technical specification

- Rated electrical power: 1.9kW
- Power supply required: 13A
- Noise level: 45dBA

Energy efficiency rating

- Energy rating: A++
- Wash rating: A
- Drying rating: A

Energy consumption

- Energy consumption per annum: 211kW.h
- Water consumption per annum: 2520L
- Energy consumption per cycle: 0.73kW.h
- Water consumption per cycle: 9L

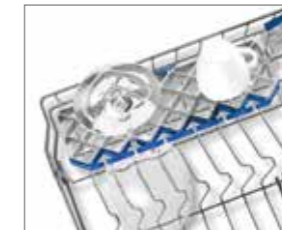

GlassGuard - wine glass supports

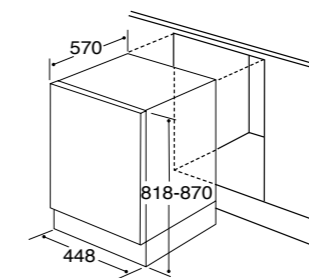



WC142
Integrated dishwasher



- Features**
- 13 place settings
 - 3/6/9 hour delay timer
 - 2 spray levels
 - LED rinse aid indicator
 - LED salt indicator
 - Acoustic signal for end of programme
 - Electronic softener adjustment
 - Levelling feet with front control
 - Height adjustable upper basket
 - White baskets

- Programmes**
- 5 programmes
 - Prewash (cold)
 - Quick wash 40°C
 - Eco 50°C
 - Super 65°C
 - Intensive 70°C

- Technical specification**
- Rated electrical power: 1.9kW
 - Power supply required: 13A
 - Noise level: 49dBA

- Energy efficiency rating**
- Energy rating: A++
 - Wash rating: A
 - Drying rating: A

- Energy consumption**
- Energy consumption per annum: 261kW.h
 - Water consumption per annum: 3360L
 - Energy consumption per cycle: 0.9kW.h
 - Water consumption per cycle: 12L

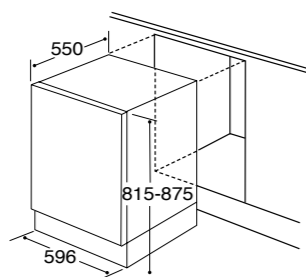

WC371
Integrated intelligent dishwasher



- Features**
- 13 place settings
 - Half load operates either upper or lower baskets individually or half load of both baskets
 - 1-19 hour delay timer
 - 3 spray levels
 - LED rinse aid indicator
 - LED salt indicator
 - Acoustic signal for end of programme
 - Electronic softener adjustment
 - 3-in-1 function
 - Levelling feet with front control
 - Height adjustable upper basket when loaded
 - GlassGuard - wine glass supports
 - Grey baskets

- Programmes**
- 9 programmes
 - Prewash (cold)
 - Quick wash 40°C
 - Eco 50°C
 - 55 minute express wash 60°C
 - Auto normal 50-60°C
 - Auto intensive 60-70°C
 - Auto delicate 30-50°C
 - Intensive 60°C
 - Intensive+ 70°C

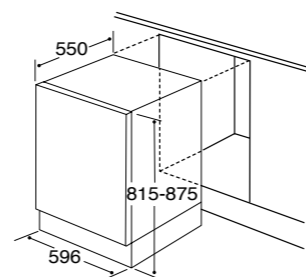

- Optional accessories**
- Variospace wine glass holder, AWG100
- Technical specification**
- Rated electrical power: 1.9kW
 - Power supply required: 13A
 - Noise level: 45dBA

- Energy efficiency rating**
- Energy rating: A++
 - Wash rating: A
 - Drying rating: A

- Energy consumption**
- Energy consumption per annum: 261kW.h
 - Water consumption per annum: 2520L
 - Energy consumption per cycle: 0.9kW.h
 - Water consumption per cycle: 9L



Top level cutlery drawer.

WC600
Integrated intelligent dishwasher



- Features**
- 15 place settings
 - LED interior light
 - Half load operates either upper or lower baskets individually or half load of both baskets
 - 1-19 hour delay timer
 - 3 spray levels
 - LED rinse aid indicator
 - LED salt indicator
 - Acoustic signal for end of programme
 - Electronic softener adjustment
 - Active drying system
 - 3-in-1 function
 - Levelling feet with front control
 - Top level cutlery basket with separate removable sections
 - Height adjustable upper basket when loaded
 - Grey baskets with easy grip handles
 - Lower basket with folding racks
 - Aquastop

- Programmes**
- 9 programmes
 - Prewash (cold)
 - Quick wash 40°C
 - Eco 50°C
 - 55 minute express wash 60°C
 - Auto normal 50-60°C
 - Auto intensive 60-70°C

- Auto delicate 30-50°C
- Intensive 60°C
- Intensive+ 70°C

- Optional accessories**
- Variospace wine glass holder, AWG100

- Technical specification**
- Rated electrical power: 1.9kW
 - Power supply required: 13A
 - Noise level: 45dBA

- Energy efficiency rating**
- Energy rating: A++
 - Wash rating: A
 - Drying rating: A

- Energy consumption**
- Energy consumption per annum: 267kW.h
 - Water consumption per annum: 2520L
 - Energy consumption per cycle: 0.94kW.h
 - Water consumption per cycle: 9L

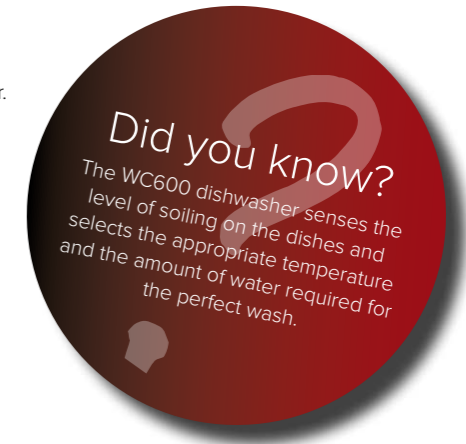
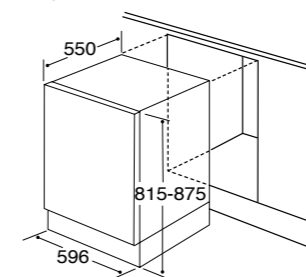

Top level cutlery drawer with easy grip handles



Variospace wine glass holder, AWG100 (optional accessory)

Laundry

All of our washing machines are A rated or better for wash performance. Being equipped with the latest programmes and features, they make efficient use of water and energy.



Look out for our models with an Eco-logic feature. These machines can detect smaller loads and will use less water and power accordingly.

Choice

CDA's range consists of both integrated and freestanding washing machines, tumble dryers and washer dryers. We are constantly testing, improving and developing our technologies to ensure that you can choose from the most energy efficient and effective appliances possible, whatever model you go for.



Quick wash

All our washers come with a quick wash option making life easier for busy families. We have pioneered super quick wash programmes that can do a wash in just 15 minutes on the CI325, CI371, CI925 and CI971 whilst the CI261 model takes just 12 minutes!



Advanced technology

High energy ratings are important on appliances like washing machines as they are in use frequently and can make up a large proportion of your energy bills. The CI261 is now rated A+++ for energy, our highest rating, meaning that you will get brilliant wash results without excessive water and energy usage.

Special wash functions help to care for your garments with every wash. Using the Delicate Wash, Easy Iron or even the Colourfast Cotton cycle will adjust the settings to look after your clothes and linens, making them last longer.

Additional digital sensors on our laundry models work with your spin cycle, water inlet and drying times to adjust the settings to achieve perfect results, every time. The Eco-logic feature even automatically adjusts the programme to suit the load and level of soiling on your wash. All this has been included to make your chores lighter and life a little easier in the home.



Quick guide to laundry

The CDA laundry range includes integrated and freestanding washing machines, washer dryers and tumble dryers.

All CDA washing machines and washer dryers have the following features:

- Robust stainless steel drum
- Safety door lock
- Cold water fill
- Integrated machines take a full height furniture door which can be hinged on the right or left

Freestanding washing machine



CI261

- 1200 spin speed
 - 9kg wash load
 - Energy rating: A+++
 - Available in white or black
- More details on p158

Freestanding washer dryer



CI860

- 1400 spin speed
 - 8 + 6kg wash load
 - Energy rating: A
- More details on p158

Freestanding tumble dryer



CI522

- 7kg drying load
 - Delicates setting
 - Reversible door
 - Energy rating: C
- More details on p159

Integrated tumble dryer



CI921

- 7kg dry load
 - 8 programmes
 - Sensor drying
 - Energy rating: C
- More details on p159

Integrated washing machines



CI325

- 1200 spin speed
 - 6kg wash load
 - Energy rating: A++
- More details on p160



CI371

- 1400 spin speed
 - 7kg wash load
 - Energy rating: A+
- More details on p160

Integrated washer dryers



CI925

- 1200 spin speed
 - 6 + 3kg wash load
 - Energy rating: B
- More details on p161



CI971

- 1400 spin speed
 - 7 + 4kg wash load
 - Energy rating: A
- More details on p161



This washing machine comes with Eco-logic, a half load detection system that uses less power and water accordingly.



White

Black

CI261
High capacity freestanding washing machine



- Features**
- 1200rpm spin speed
 - 15 programmes
 - 9kg wash load
 - Delay timer
 - Variable spin speed
 - Variable wash temperature
 - Eco-logic
 - LCD display
 - 12 minute quick wash function
 - Delicates wash function
 - Twin jet
 - Anti-flooding safety
 - Safety key lock
 - Anti-crease function
 - Clean pump filter indicator
 - Failure detection system

- Water consumption per cycle: 57L
- Energy consumption per annum: 211kW.h
- Water consumption per annum: 12320L

- Available in**
- White
 - Black

- Technical specification**
- Rated electrical power: 2.2kW
 - Power supply required: 13A
 - Noise level: wash 58 / spin 78dBA

- Energy efficiency rating**
- Energy rating: A+++
 - Wash rating: A
 - Spin rating: B

- Energy consumption**
- Energy consumption per cycle: 1.03kW.h

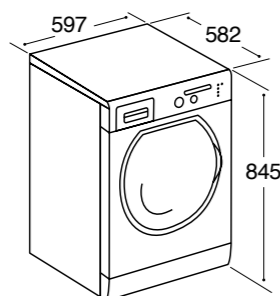

This washer dryer comes with Eco-logic, a half load detection system that uses less power and water accordingly.

CI860
High capacity freestanding washer dryer



- Features**
- 1400rpm spin speed
 - 15 programmes
 - 8kg wash load
 - 6kg dry load
 - Delay timer
 - Variable spin speed
 - Variable wash temperature
 - Eco-logic
 - LCD display
 - LCD progress indicator
 - 15 minute quick wash function
 - Extra rinse function
 - Easy iron function
 - Delicates drying function
 - Condensing dryer
 - Overflow protection
 - Safety key lock
 - Balance control
 - Allergysafe function

- cycle: 5.44kW.h
- Water consumption per cycle: 112L
- Energy consumption per annum: 1197kW.h
- Water consumption per annum: 24640L

- Available in**
- White

- Technical specification**
- Rated electrical power: 2.2kW
 - Power supply required: 13A
 - Noise level: wash 58 / spin 77 / dry 64dBA

- Energy efficiency rating**
- Energy rating: A
 - Wash rating: A

- Energy consumption**
- Energy consumption per

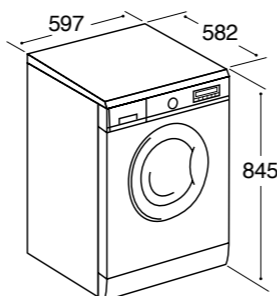

CI522
Freestanding tumble dryer



- Features**
- 7kg dry load
 - Analogue progress indicator
 - Vented dryer
 - Variable drying duration
 - Delicates setting
 - Reversible door

- Available in**
- White

- Technical specification**
- Rated electrical power: 2.7kW
 - Power supply required: 13A
 - Noise level: 62dBA

- Energy efficiency rating**
- Energy rating: C

- Energy consumption**
- Energy consumption per cycle: 4.48kW.h
 - Energy consumption per annum: 519kW.h

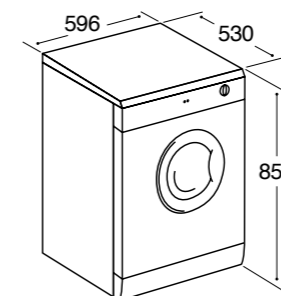

CI921
Integrated tumble dryer



- Features**
- 7kg dry load
 - Sensor dryer
 - Vented dryer
 - 2 heat settings
 - Reversible door
 - 8 programmes
 - Safety key lock
 - Timed drying programme
 - Airing programme

- Available in**
- White

- Technical specification**
- Rated electrical power: 2kW
 - Power supply required: 13A
 - Noise level: 62dBA

- Energy efficiency rating**
- Energy rating: C

- Energy consumption**
- Energy consumption per cycle: 4.39kW.h
 - Energy consumption per annum: 519kW.h

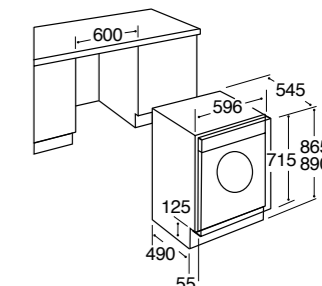



CI325
Integrated washing machine



- Features
- 1200rpm spin speed
 - 11 programmes
 - 6kg wash load
 - Delay timer
 - Variable spin speed
 - Variable wash temperature
 - 15 minute quick wash function
 - Delicates wash function
 - Cold wash
 - Wool wash
 - LED display
 - Safety key lock
 - Anti-crease function
 - Extra rinse function
 - Intensive wash function
 - Acoustic signal for end of programme

- Water consumption per cycle: 50L
- Energy consumption per annum: 166kW.h
- Water consumption per annum: 11003L

- Available in
- White

- Technical specification
- Rated electrical power: 2kW
 - Power supply required: 13A
 - Noise level: wash 57 / spin 75dBA

- Energy efficiency rating
- Energy rating: A++
 - Wash rating: A
 - Spin rating: B

- Energy consumption
- Energy consumption per cycle: 0.80kW.h

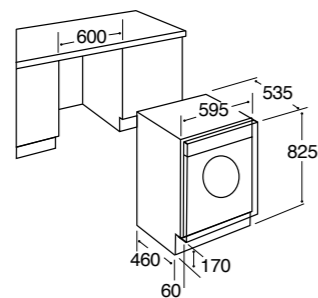

CI371
Integrated washing machine



- Features
- 1400rpm spin speed
 - 15 programmes
 - 7kg wash load
 - Delay timer
 - Variable spin speed
 - Intelligent spin control
 - Flexible quick wash function
 - Delicates wash function
 - Cold wash
 - Wool wash
 - LED display
 - Safety key lock
 - Anti-crease function
 - Extra rinse function
 - Easy iron function
 - Intensive wash function
 - Acoustic signal for end of programme
 - Balance control
 - Total aquastop

- Available in
- White

- Technical specification
- Rated electrical power: 2.2kW
 - Power supply required: 13A
 - Noise level: wash 56 / spin 72dBA

- Energy efficiency rating
- Energy rating: A+
 - Wash rating: A
 - Spin rating: B

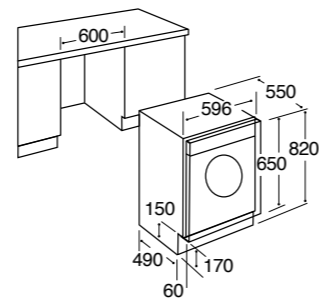

CI925
Integrated washer dryer



- Features
- 1200rpm spin speed
 - 11 programmes
 - 6kg wash load
 - 3kg dry load
 - Delay timer
 - Variable spin speed
 - Variable wash temperature
 - 15 minute quick wash function
 - Intensive wash function
 - Extra rinse function
 - Drum clean programme
 - Condensing dryer
 - Acoustic signal for end of programme
 - LED display
 - Safety key lock

- Available in
- White

- Technical specification
- Rated electrical power: 2kW
 - Power supply required: 13A
 - Noise level: wash 59 / spin 76 / dry 58dBA

- Energy efficiency rating
- Energy rating: B
 - Wash rating: A

- Energy consumption
- Energy consumption per cycle: 4.85kW.h
 - Water consumption per cycle: 108L

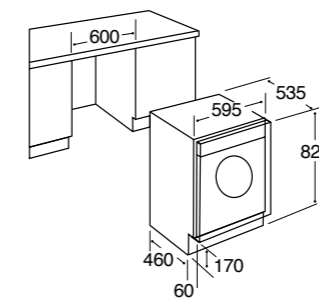

CI971
Integrated washer dryer



- Features
- 1400rpm spin speed
 - 15 programmes
 - 7kg wash load
 - 4kg dry load
 - Delay timer
 - Variable spin speed
 - Intelligent spin control
 - Flexible quick wash function
 - Delicates setting
 - LED display
 - Anti-crease function
 - Extra rinse function
 - Easy iron function
 - Intensive wash function
 - Condensing dryer
 - Acoustic signal for end of programme
 - Variable drying duration
 - Safety key lock
 - Balance control
 - Anti-flooding safety
 - Total aquastop

- Available in
- White

- Technical specification
- Rated electrical power: 2.2kW
 - Power supply required: 13A
 - Noise level: wash 56 / spin 72 / dry 58dBA

- Energy efficiency rating
- Energy rating: A
 - Wash rating: A

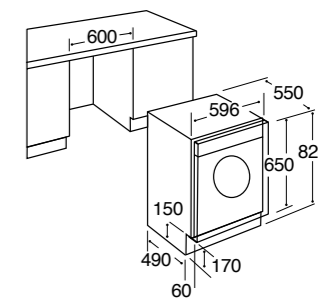

Sinks

The CDA sink range includes stainless steel, composite, ceramic and glass in either contemporary or traditional designs to suit any kitchen.



Our comprehensive sink range offers maximum impact combined with cutting edge technology - the K980 even has Ariapura where titanium dioxide nanoparticles actively purify the air around your sink.

Stainless steel

All CDA sinks are constructed from premium 304 grade stainless steel for superb quality. Stainless steel is resistant to heat and household chemicals, and is easy to clean. It has a smooth, non-porous surface making it very practical and hygienic.



Glass

The stunning KVL02 is an innovative glass sink which co-ordinates perfectly with our black glass appliances and hobs. It is constructed from robust scratch, stain and heat resistant glass and finished with an elegant bevelled edge.



Composite

Made from a mixture of quartz or granite blended with acrylic resin for durability, our composite sinks are hard wearing and combine the natural look of stone with the benefits of a modern material.



Ceramic

Made from incredibly robust, fine fireclay with a hard, glossy finish, these sinks are easy to clean and extremely durable. Our choice of styles includes contemporary single or one and a half bowl sinks, traditional Belfast styles and even ceramic undermount sinks.



Undermount sinks

If you are looking for something a little more streamlined, then an undermount sink is the way to go. The sink is designed to fit with the worktops overlapping the edges, for a seamless finish. You can still have the option of steel, ceramic or composite and you needn't compromise on size either, with one and a half bowl sizes available.

Quick guide to sinks

The CDA range of sinks includes stainless steel, ceramic, composite and even glass models. Undermount sinks are also available in stainless steel, composite or ceramic materials.

Most CDA sinks are supplied with pipework included and have large 3.5" strainer wastes.

Stainless steel sinks

All stainless steel sinks from CDA are manufactured from premium quality 304 grade steel. This gives the sink a high resistance to corrosion and rust, with the ability to withstand all common household detergents. They are also extremely hygienic and easy to clean.

Ceramic sinks

CDA ceramic sinks have a hard, non-porous surface with a tough, gloss finish. They are extremely durable and are resistant to both chemicals and heat. We offer a variety of styles from contemporary to traditional, including the classic "Belfast" model, available in both a single and double bowl option.

Please note: Ceramic sinks are traditionally made and each one will have individual characteristics. This may cause dimensions to vary from those shown in the brochure by between 2 and 5%.

Composite sinks

Our composite sinks are made of natural granite or quartz combined with acrylic resin to give a durable and hard wearing sink.

Like the natural stone, particles of granite combined with resin give these sinks an authentic flecked finish that is incredibly hard wearing.

Accessories

Look out for the useful optional accessories which are available to help make your life easy. Our accessories are designed to work perfectly with the compatible sinks.

Undermount sinks

Also available but not shown in detail here:



undermount sink range

See p184-195

Stainless steel



KR20

- Single round drainer
- Fits in 450mm base unit
- More details on p166



KR21

- Single round bowl sink
- Fits in 450mm base unit
- More details on p166



KA30

- Compact single bowl sink
- Reversible
- Fits in 500mm base unit
- More details on p169



KA32

- One and a half bowl sink
- Reversible
- Fits in 600mm base unit
- More details on p169



KA71

- Large single bowl sink
- Reversible
- Fits in 600mm base unit
- More details on p171



KA72

- One and a half bowl sink
- Reversible
- Fits in 600mm base unit
- More details on p172



KVL01/KVL01L

- Glass single bowl sink
- Scratch, stain and heat resistant
- Fits in 600mm base unit
- More details on p174



KVL02/KVL02L

- Glass one and a half bowl sink
- Scratch, stain and heat resistant
- Fits in 800mm base unit
- More details on p175



KG73

- Composite single bowl sink
- Granite/quartz construction
- Fits in 600mm base unit
- Reversible
- Available in anthracite or graphite
- More details on p177



KG74

- Composite one and a half bowl sink
- Granite/quartz construction
- Fits in 600mm base unit
- Reversible
- Available in anthracite or graphite
- More details on p178



KC11

- Ceramic Belfast single bowl sink
- Fireclay construction
- More details on p180



KC12

- Ceramic Belfast double bowl sink
- Fireclay construction
- More details on p181



CCP3

- Double bowl corner sink
- Polished finish
- More details on p167



KA55

- Single bowl sink with mini drainer
- Reversible
- Fits in 450mm base unit
- More details on p170



KA80

- Single bowl sink
- Reversible
- Fits in 500mm base unit
- More details on p172



AS1

- Composite single bowl sink
- Composite granite construction
- Fits in 450mm base unit
- Reversible
- Available in white or cream
- More details on p175



KG81

- Composite single bowl sink with stainless steel drainer bars
- Granite/quartz construction
- Fits in 600mm base unit
- Reversible
- Available in anthracite or graphite
- More details on p178



KC23

- Ceramic single bowl sink
- Heavy duty
- Reversible
- Fits in 600mm base unit
- More details on p182



KA20

- Compact single bowl sink
- Reversible
- Fits in 450mm base unit
- More details on p167



KA50

- Compact single bowl sink
- Reversible
- Fits in 450mm base unit
- More details on p170



KA82

- One and a half bowl sink
- Reversible
- Fits in 600mm base unit
- More details on p173



AS2

- Composite one and a half bowl sink
- Composite granite construction
- Fits in 600mm base unit
- Reversible
- Available in white or cream
- More details on p176



KG82

- Composite one and a half bowl sink with stainless steel drainer bars
- Granite/quartz construction
- Fits in 600mm base unit
- Reversible
- Available in anthracite or graphite
- More details on p179



KC24

- Ceramic one and a half bowl sink
- Heavy duty
- Reversible
- Fits in 600mm base unit
- More details on p182



KA21

- Single bowl sink
- Reversible
- Fits in 450mm base unit
- More details on p168



KA52

- One and a half bowl sink
- Reversible
- Fits in 600mm base unit
- More details on p171



KVF21R/KVF21L

- Single bowl flush-fit sink
- Slim top profile
- Fits in 600mm base unit
- More details on p173



KG43

- Composite single bowl sink
- Granite/quartz construction
- Reversible
- Fits in 600mm base unit
- More details on p176



KG80

- Composite double bowl sink with metallic finish
- Ariapura technology
- Fits in 900mm base unit
- More details on p179



KC73

- Ceramic classic design single bowl sink
- Heavy duty
- Reversible
- Fits in 600mm base unit
- More details on p183



KA22

- One and a half bowl sink
- Reversible
- Fits in 600mm base unit
- More details on p168



KVF22R/KVF22L

- One and a half bowl flush-fit sink
- Slim top profile
- Fits in 600mm base unit
- More details on p174



KG44

- Composite one and a half bowl sink
- Granite/quartz construction
- Reversible
- Fits in 600mm base unit
- More details on p177

Ceramic



KC10

- Ceramic Belfast single bowl sink with weir overflow
- Fireclay construction
- More details on p180



KC74

- Ceramic classic design one and a half bowl sink
- Heavy duty
- Reversible
- Fits in 600mm base unit
- More details on p183



KR20
Stainless steel round drainer

- Features**
- Polished finish
- Accessories**
- Waste kit
 - Plumbing pack
- Optional accessories**
- Waste disposer, AKD01/ AKD02
 - Space saver plumbing pack, PP1
- Available in**
- Stainless steel

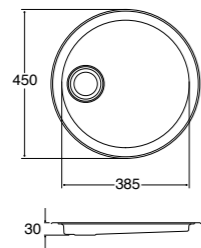

KR21
Stainless steel round single bowl sink

- Features**
- Polished finish
 - Fits in 450mm base unit
- Accessories**
- Waste kit
 - Plumbing pack
- Optional accessories**
- Stainless steel basket, AKB05
 - Wooden chopping board, AKW05
 - Waste disposer, AKD01/ AKD02
 - Space saver plumbing pack, PP1
- Available in**
- Stainless steel

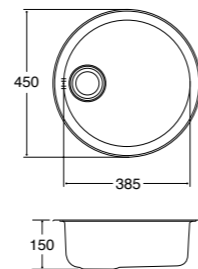

CCP3
Stainless steel corner double bowl sink

- Features**
- Polished finish
 - 1mm heavy gauge stainless steel construction
- Optional accessories**
- Wooden chopping board, TRE
 - Waste disposer, AKD01/ AKD02
 - Space saver plumbing pack, PP2
- Available in**
- Stainless steel

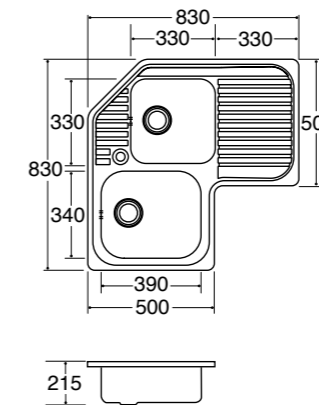

KA20
Stainless steel compact single bowl sink

- Features**
- Polished finish
 - Reversible
 - Fits in 450mm base unit
- Accessories**
- Waste kit
 - Plumbing pack
- Optional accessories**
- Wooden chopping board, AKW20
 - Waste disposer, AKD01/ AKD02
 - Space saver plumbing pack, PP1
- Available in**
- Stainless steel

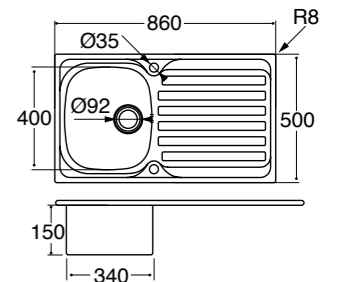

Optional accessories

The AKW20 wooden chopping board is the perfect accessory for the KA20, KA21 and KA22 sinks.





KA21
Stainless steel single bowl sink

Features

- Polished finish
- Reversible
- Fits in 450mm base unit

Accessories

- Waste kit
- Plumbing pack

Optional accessories

- Wooden chopping board, AKW20
- Waste disposer, AKD01/ AKD02
- Space saver plumbing pack, PP1

- Available in
- Stainless steel

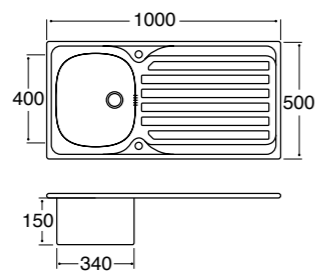

Optional accessories

The AKW20 wooden chopping board is the perfect accessory for the KA20, KA21 and KA22 sinks.



KA22
Stainless steel one and a half bowl sink

Features

- Polished finish
- Reversible
- Fits in 600mm base unit

Accessories

- Waste kit
- Plumbing pack

Optional accessories

- Wooden chopping board, AKW20
- Waste disposer, AKD01/ AKD02
- Space saver plumbing pack, PP2

- Available in
- Stainless steel

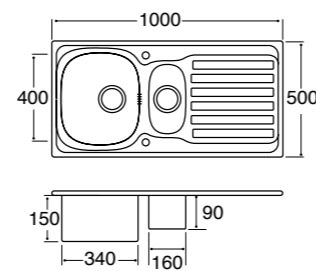

Optional accessories

The AKW20 wooden chopping board is the perfect accessory for the KA20, KA21 and KA22 sinks.



KA30
Stainless steel compact single bowl sink

Features

- Polished finish
- Reversible
- Fits in 500mm base unit

Accessories

- Waste kit
- Plumbing pack

Optional accessories

- Sliding wooden chopping board, AKW38
- Waste disposer, AKD01/ AKD02
- Space saver plumbing pack, PP1

- Available in
- Stainless steel

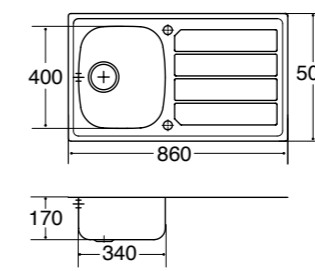

Optional accessories

The AKW38 sliding wooden chopping board is the perfect accessory for the KA30 sink.



KA32
Stainless steel one and a half bowl sink

Features

- Polished finish
- Reversible
- Fits in 600mm base unit

Accessories

- Waste kit
- Plumbing pack

Optional accessories

- Sliding wooden chopping board, AKW38
- Stainless steel basket, AKB38
- Waste disposer, AKD01/ AKD02
- Space saver plumbing pack, PP2

- Available in
- Stainless steel

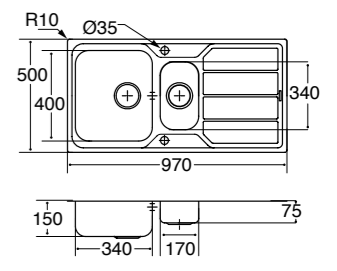

Optional accessories

The AKB38 stainless steel basket and AKW38 sliding wooden chopping board are the perfect accessories for the KA30, KA32, KA80 and KA82 sinks.

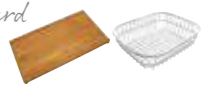



KA55
Stainless steel single bowl sink with mini drainer

Features

- Polished finish
- Reversible
- Fits in 450mm base unit

Accessories

- Waste kit
- Plumbing pack

Optional accessories

- Wooden chopping board, AKW57
- Stainless steel basket, AKB57
- Waste disposer, AKD01/ AKD02
- Space saver plumbing pack, PP1

Available in

- Stainless steel

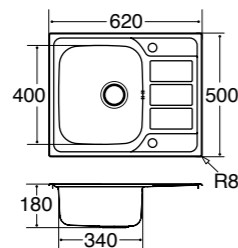

Optional accessories

The AKW57 wooden chopping board and AKB57 stainless steel basket are the perfect accessories for the KA55, KA50, KA52 and KA72 sinks.

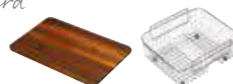

KA50
Stainless steel compact single bowl sink

Features

- Polished finish
- Reversible
- Fits in 450mm base unit

Accessories

- Waste kit
- Plumbing pack

Optional accessories

- Wooden chopping board, AKW57
- Stainless steel basket, AKB57
- Waste disposer, AKD01/ AKD02
- Space saver plumbing pack, PP1

Available in

- Stainless steel

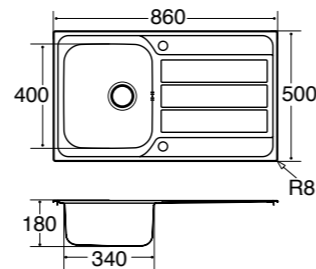

Optional accessories

The AKW57 wooden chopping board and AKB57 stainless steel basket are the perfect accessories for the KA55, KA50, KA52 and KA72 sinks.

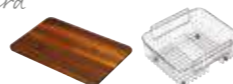

KA52
Stainless steel one and a half bowl sink

Features

- Polished finish
- Reversible
- Fits in 600mm base unit

Accessories

- Waste kit
- Plumbing pack

Optional accessories

- Wooden chopping board, AKW57
- Stainless steel basket, AKB57
- Waste disposer, AKD01/ AKD02
- Space saver plumbing pack, PP2

Available in

- Stainless steel

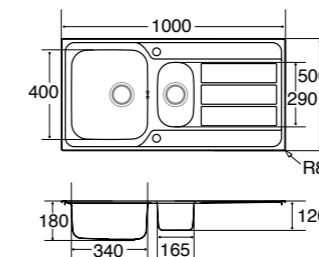

Optional accessories

The AKW57 wooden chopping board and AKB57 stainless steel basket are the perfect accessories for the KA55, KA50, KA52 and KA72 sinks.

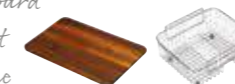

KA71
Stainless steel large single bowl sink

Features

- Polished finish
- Reversible
- Extra large bowl
- Fits in 600mm base unit

Accessories

- Waste kit
- Plumbing pack

Optional accessories

- Wooden chopping board, AKW03
- Waste disposer, AKD01/ AKD02
- Space saver plumbing pack, PP1

Available in

- Stainless steel

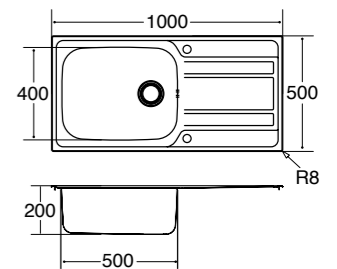

Optional accessories

The AKW03 wooden chopping board is the perfect accessory for the KA71 sink.





KA72
Stainless steel one and a half bowl sink

- Features
- Polished finish
 - Reversible
 - Fits in 600mm base unit

Accessories

- Waste kit
- Plumbing pack

Optional accessories

- Wooden chopping board, AKW57
- Stainless steel basket, AKB57
- Waste disposer, AKD01/ AKD02
- Space saver plumbing pack, PP2

- Available in
- Stainless steel

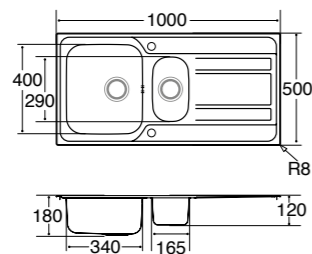

Optional accessories

The AKW57 wooden chopping board and AKB57 stainless steel basket are the perfect accessories for the KAS5, KAS0, KAS2 and KA72 sinks.

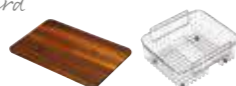

KA80
Stainless steel single bowl sink

- Features
- Satinised finish for an extra smooth, easy to clean surface
 - Reversible
 - Fits in 500mm base unit
 - Larger bowl
 - Recessed water-safe perimeter profile
 - Noise deadening pads

Accessories

- Waste kit
- Plumbing pack

- Optional accessories
- Sliding wooden chopping board, AKW38
 - Stainless steel basket, AKB38
 - Waste disposer, AKD01/ AKD02
 - Space saver plumbing pack, PP1

Optional accessories

The AKB38 stainless steel basket and AKW38 sliding wooden chopping board are the perfect accessories for the KA30, KA32, KA80 and KA82 sinks.

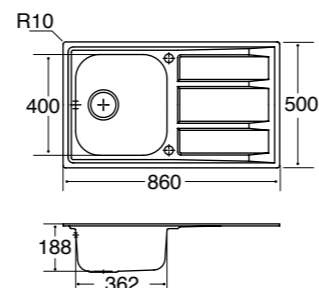
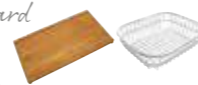

KA82
Stainless steel one and a half bowl sink

- Features
- Satinised finish for an extra smooth, easy to clean surface
 - Reversible
 - Fits in 600mm base unit
 - Recessed water-safe perimeter profile
 - Noise deadening pads

Accessories

- Waste kit
- Plumbing pack

Optional accessories

- Sliding wooden chopping board, AKW38
- Stainless steel basket, AKB38
- Waste disposer, AKD01/ AKD02
- Space saver plumbing pack, PP2

Optional accessories

The AKB38 stainless steel basket and AKW38 sliding wooden chopping board are the perfect accessories for the KA30, KA32, KA80 and KA82 sinks.

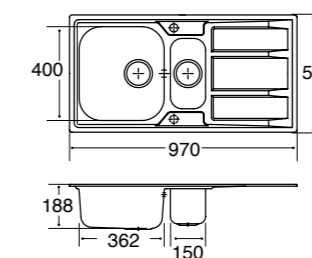

KVF21R



KVF21L

KVF21
Single bowl flush-fit sink

- Features
- Extra large bowl
 - Flush-fit, slim top profile
 - Fits in 600mm base unit
 - 1mm heavy gauge stainless steel construction
 - Noise deadening pads

Accessories

- Concealed overflow
- Waste kit
- Plumbing pack

Optional accessories

- Stainless steel main bowl colander, AKC12
- Waste disposer, AKD01/ AKD02
- Space saver plumbing pack, PP1

Optional accessories

The AKC12 stainless steel main bowl colander is the perfect accessory for KVF21, KVF22*, KVL01 and KVL02* sinks.

* Fits the main bowl only.

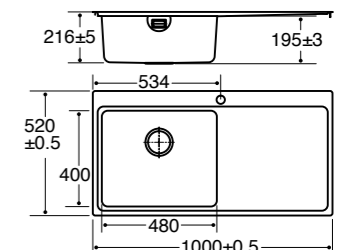

Sleek Lines
 This heavy grade, minimally styled sink is designed to fit flush with your worktops creating a stylish and contemporary look.



KVF22R

KVL01

KVL02

White



KVF22L

KVL01L

KVL02L

Cream

KVF22
 One and a half bowl flush-fit sink

KVL01
 Glass single bowl sink

KVL02
 Glass one and a half bowl sink

AS1
 Composite single bowl sink

- Features**
- Flush-fit, slim top profile
 - Fits in 600mm base unit
 - 1mm heavy gauge stainless steel construction
 - Noise deadening pads

- Available in**
- Stainless steel - right hand drainer, KVF22R
 - Stainless steel - left hand drainer, KVF22L

- Features**
- Extra large bowl
 - Toughened glass
 - Scratch, stain and heat resistant
 - Fits in 600mm base unit
 - Noise deadening pads

- Available in**
- Black - right hand drainer, KVL01
 - Black - left hand drainer, KVL01L

- Features**
- Toughened glass
 - Scratch, stain and heat resistant
 - Fits in 800mm base unit
 - Noise deadening pads

- Available in**
- Black - right hand drainer, KVL02
 - Black - left hand drainer, KVL02L

- Features**
- Composite granite construction
 - Scratch resistant
 - Reversible
 - Fits in 450mm base unit

- Accessories**
- Concealed overflow
 - Waste kit
 - Plumbing pack

- Accessories**
- Concealed overflow
 - Waste kit
 - Plumbing pack

- Accessories**
- Concealed overflow
 - Waste kit
 - Plumbing pack

- Accessories**
- Waste kit
 - Plumbing pack

- Optional accessories**
- Stainless steel main bowl colander, AKC12
 - Waste disposer, AKD01/ AKD02
 - Space saver plumbing pack, PP2

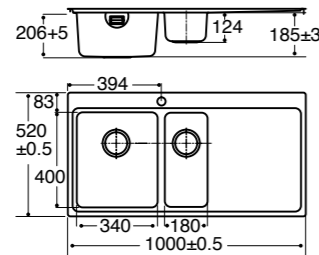

- Optional accessories**
- Stainless steel main bowl colander, AKC12
 - Waste disposer, AKD01/ AKD02
 - Space saver plumbing pack, PP1

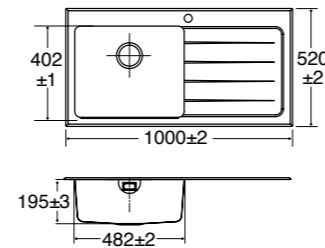

- Optional accessories**
- Stainless steel main bowl colander, AKC12
 - Waste disposer, AKD01/ AKD02
 - Space saver plumbing pack, PP2

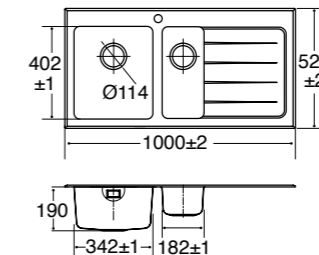

- Optional accessories**
- Accessory pack: stainless steel main bowl basket, wooden chopping board, PA1
 - Waste disposer, AKD01/ AKD02
 - Space saver plumbing pack, PP1

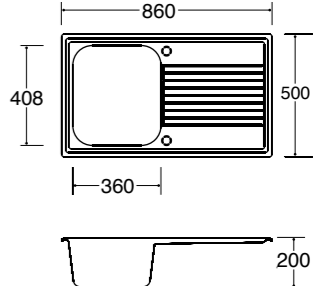

- Available in**
- White
 - Cream

Optional accessories

The AKC12 stainless steel main bowl colander is the perfect accessory for KVF21, KVF22*, KVL01 and KVL02* sinks.

*Fits the main bowl only.



Optional accessories

The AKC12 stainless steel main bowl colander is the perfect accessory for KVF21, KVF22*, KVL01 and KVL02* sinks.

*Fits the main bowl only.



Optional accessories

The AKC12 stainless steel main bowl colander is the perfect accessory for KVF21, KVF22*, KVL01 and KVL02* sinks.

*Fits the main bowl only.



Optional accessories

The PA1 sink accessory pack contains a stainless steel main bowl basket and wooden chopping board.



Did you know?
Our new composite sink range can withstand temperatures of up to 280°C and are produced from one of nature's hardest materials - quartz.



White



Anthracite



Cream



Graphite

AS2
Composite one and a half bowl sink

KG43
Composite single bowl sink

KG44
Composite one and a half bowl sink

KG73
Composite single bowl sink

- Features**
- Composite granite construction
 - Scratch resistant
 - Reversible
 - Fits in 600mm base unit

- Available in**
- White
 - Cream

- Accessories**
- Waste kit
 - Plumbing pack

- Optional accessories**
- Accessory pack: stainless steel main bowl basket, small stainless basket, wooden chopping board, PA2
 - Waste disposer, AKD01/ AKD02
 - Space saver plumbing pack, PP2

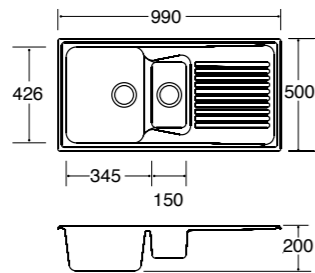

- Features**
- Granite/quartz construction
 - Scratch resistant
 - Tough and hygienic
 - Super smooth metallic finish
 - Reversible
 - Fits in 600mm base unit
 - New and exclusive strainer design

- Space saver plumbing pack, PP1
- Available in**
- Anthracite

- Accessories**
- Concealed overflow
 - Waste kit
 - Plumbing pack

- Optional accessories**
- Black glass chopping board, AKG47
 - Stainless steel main bowl colander, AKC48
 - Waste disposer, AKD01/ AKD02

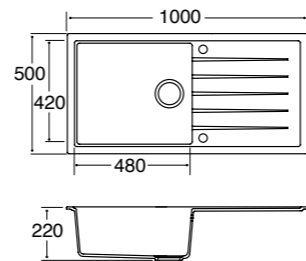

- Features**
- Granite/quartz construction
 - Scratch resistant
 - Tough and hygienic
 - Super smooth metallic finish
 - Reversible
 - Fits in 600mm base unit
 - New and exclusive strainer design

- Space saver plumbing pack, PP2
- Available in**
- Anthracite

- Accessories**
- Concealed overflow
 - Waste kit
 - Plumbing pack

- Optional accessories**
- Black glass chopping board, AKG47
 - Stainless steel main bowl colander, AKC48
 - Waste disposer, AKD01/ AKD02

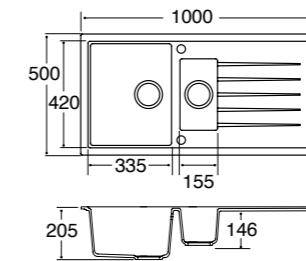

- Features**
- Granite/quartz construction
 - Scratch resistant
 - Tough and hygienic
 - Super smooth metallic finish
 - Reversible
 - Fits in 600mm base unit
 - New and exclusive strainer design

- Space saver plumbing pack, PP1
- Available in**
- Anthracite
 - Graphite

- Accessories**
- Concealed overflow
 - Waste kit
 - Plumbing pack

- Optional accessories**
- Black glass chopping board, AKG47
 - Stainless steel main bowl colander, AKC48
 - Waste disposer, AKD01/ AKD02

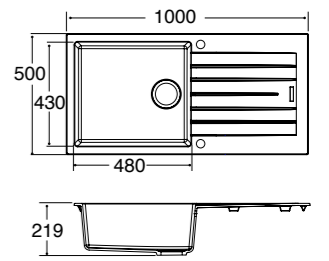

Optional accessories

The PA2 sink accessory pack contains a stainless steel main bowl basket, stainless steel half bowl basket and wooden chopping board.



Optional accessories

The AKG47 glass chopping board and AKC48 stainless steel main bowl colander make preparing food quick and easy.

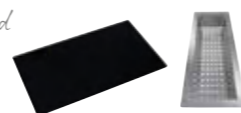

Optional accessories

The AKG47 glass chopping board and AKC48 stainless steel main bowl colander make preparing food quick and easy.



Optional accessories

The AKG47 glass chopping board and AKC48 stainless steel main bowl colander make preparing food quick and easy.

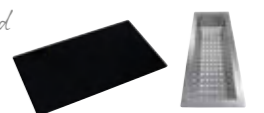

A built-in stainless steel trivet finishes off the design perfectly as well as offering a practical trivet for cookware.



Anthracite



Anthracite



Anthracite



Black



Graphite



Graphite



Graphite



Black glass chopping boards, AKG80BL

KG74
Composite one and a half bowl sink

- Features**
- Granite/quartz construction
 - Scratch resistant
 - Tough and hygienic
 - Super smooth metallic finish
 - Reversible
 - Fits in 600mm base unit
 - New and exclusive strainer design

- Accessories**
- Concealed overflow
 - Waste kit
 - Plumbing pack

- Optional accessories**
- Black glass chopping board, AKG47
 - Stainless steel main bowl colander, AKC48
 - Waste disposer, AKD01/AKD02

- Space saver plumbing pack, PP2
- Available in**
- Anthracite
 - Graphite

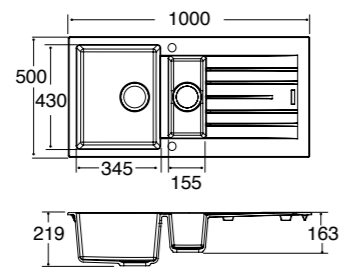

Optional accessories

The AKG47 glass chopping board and AKC48 stainless steel main bowl colander make preparing food quick and easy.



KG81
Composite single bowl sink with stainless steel drainer bars

- Features**
- Granite/quartz construction
 - Scratch resistant
 - Tough and hygienic
 - Super smooth metallic finish
 - Reversible
 - Fits in 600mm base unit
 - New and exclusive strainer design
 - Stainless steel drainer bars

- Accessories**
- Concealed overflow
 - Waste kit
 - Plumbing pack

- Optional accessories**
- Black glass chopping board, AKG47
 - Stainless steel main bowl colander, AKC48

- Waste disposer, AKD01/AKD02
 - Space saver plumbing pack, PP1
- Available in**
- Anthracite
 - Graphite

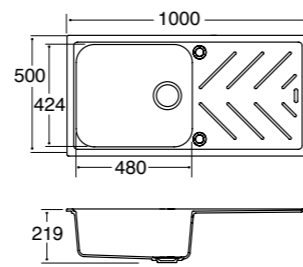

Optional accessories

The AKG47 glass chopping board and AKC48 stainless steel main bowl colander make preparing food quick and easy.



KG82
Composite one and a half bowl sink with stainless steel drainer bars

- Features**
- Granite/quartz construction
 - Scratch resistant
 - Tough and hygienic
 - Super smooth metallic finish
 - Reversible
 - Fits in 600mm base unit
 - New and exclusive strainer design
 - Stainless steel drainer bars

- Accessories**
- Concealed overflow
 - Waste kit
 - Plumbing pack

- Optional accessories**
- Black glass chopping board, AKG47
 - Stainless steel main bowl colander, AKC48

- Waste disposer, AKD01/AKD02
 - Space saver plumbing pack, PP2
- Available in**
- Anthracite
 - Graphite

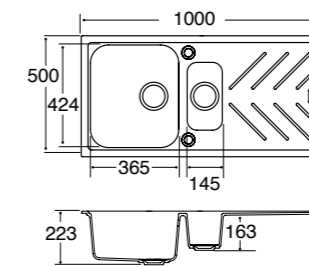

Optional accessories

The AKG47 glass chopping board and AKC48 stainless steel main bowl colander make preparing food quick and easy.



CDA's KG80 sink features Ariapura technology. The composition includes titanium dioxide that actively purifies the air around your sink using natural light, transforming pollutants into harmless mineral salts. It also provides antibacterial protection, supporting the cleanliness of your home environment.

KG80
Composite double bowl sink

- Features**
- Granite/quartz construction
 - Scratch resistant
 - Tough and hygienic
 - Super smooth metallic finish
 - Antibacterial protection for a cleaner, safer sink
 - Contains titanium micro-particles to purify the air around the sink for extreme freshness
 - Fits in 900mm base unit

- Accessories**
- Waste kit
 - Plumbing pack

- Optional accessories**
- Pack of 2 glass chopping boards (black), AKG80BL
 - Pack of 2 glass chopping boards (mirror), AKG80MR

- Stainless steel colander, AKC80
 - Strainer waste cover, AKS80
- Available in**
- Black



Strainer waste cover, AKS80

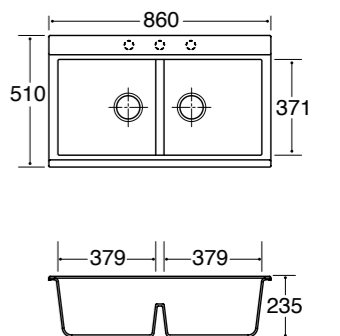

With a weir overflow located at the side of this model and a straight sided bowl, the KC10 is a true "Belfast" sink in design. Combine with a TT56 bridge tap for definitive traditional style.



KC10
Ceramic Belfast sink

Features

- Classic design
- Fireclay construction
- Suitable for over or under mounting

Accessories

- Waste kit
- Plumbing pack

Optional accessories

- Space saver plumbing pack, PP1

Available in

- White

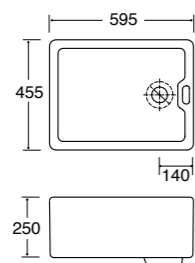

PLEASE NOTE: DIMENSIONS
MAY DIFFER BY UP TO 5%

Handmade fireclay sink.



KC11
Ceramic Belfast style sink

Features

- Classic design
- Fireclay construction

Accessories

- Waste kit
- Plumbing pack

Optional accessories

- Space saver plumbing pack, PP1

Available in

- White

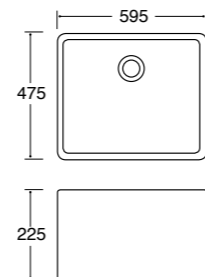

PLEASE NOTE: DIMENSIONS
MAY DIFFER BY UP TO 5%

A handmade fireclay sink is very hard wearing. It is traditionally made, and each one will have individual characteristics. The dimensions may vary slightly and there are likely to be natural marks under the glaze giving real character.



KC12
Ceramic Belfast style double bowl sink

Features

- Classic design
- Fireclay construction

Accessories

- Waste kit
- Plumbing pack

Optional accessories

- Waste disposer and adaptor, AKD01/AKD02 and AKD03
- Space saver plumbing pack, PP2

Available in

- White

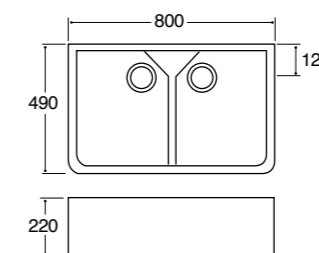

PLEASE NOTE: DIMENSIONS
MAY DIFFER BY UP TO 5%

Handmade fireclay sink.



Handmade fireclay sink.



Handmade fireclay sink.



Handmade fireclay sink.



KC23
Ceramic single bowl sink

- Features
- Classic design
 - Heavy duty
 - Reversible
 - Fits in 600mm base unit

- Accessories
- Waste kit
 - Plumbing pack

- Optional accessories
- Waste disposer and adaptor, AKD01/AKD02 and AKD03
 - Space saver plumbing pack, PP1

- Available in
- White

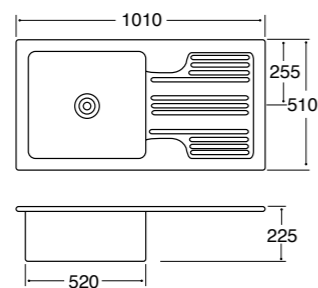

PLEASE NOTE: DIMENSIONS MAY DIFFER BY UP TO 5%

KC24
Ceramic one and a half bowl sink

- Features
- Classic design
 - Heavy duty
 - Reversible
 - Fits in 600mm base unit

- Accessories
- Waste kit
 - Plumbing pack

- Optional accessories
- Waste disposer and adaptor, AKD01/AKD02 and AKD03
 - Space saver plumbing pack, PP2

- Available in
- White

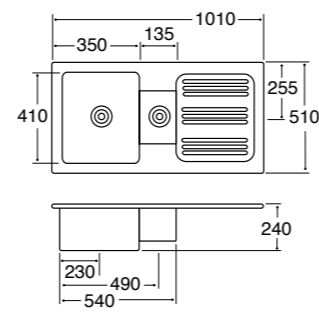

PLEASE NOTE: DIMENSIONS MAY DIFFER BY UP TO 5%

KC73
Ceramic single bowl sink

- Features
- Classic design
 - Heavy duty
 - Large bowl
 - Reversible
 - Fits in 600mm base unit

- Accessories
- Waste kit
 - Plumbing pack

- Optional accessories
- Waste disposer and adaptor, AKD01/AKD02 and AKD03
 - Space saver plumbing pack, PP1

- Available in
- White

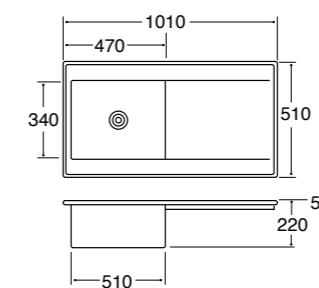

PLEASE NOTE: DIMENSIONS MAY DIFFER BY UP TO 5%

KC74
Ceramic one and a half bowl sink

- Features
- Classic design
 - Heavy duty
 - Reversible
 - Fits in 600mm base unit

- Accessories
- Waste kit
 - Plumbing pack

- Optional accessories
- Waste disposer and adaptor, AKD01/AKD02 and AKD03
 - Space saver plumbing pack, PP2

- Available in
- White

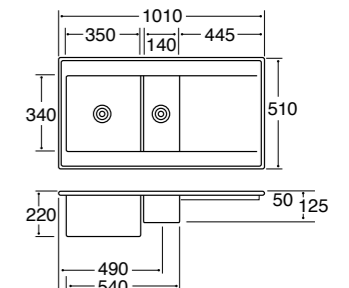

PLEASE NOTE: DIMENSIONS MAY DIFFER BY UP TO 5%

Full undermount sinks range

CDA undermounts are available in a wide variety of sizes, styles and materials, to suit most kitchen designs.

Stainless steel



- KCC21**
- Half bowl undermount sink
 - Polished finish
 - Easy fixing system
- More details on p186



- KCC22**
- Three quarter bowl undermount sink
 - Polished finish
 - Easy fixing system
- More details on p186



- KCC23**
- Single bowl undermount sink
 - Polished finish
 - Easy fixing system
- More details on p187



- KCC24**
- Rectangular bowl undermount sink
 - Polished finish
 - Easy fixing system
- More details on p188



- KCC27**
- One and a half bowl undermount sink
 - Noise deadening pads
 - Easy fixing system
- More details on p188



- KCC28**
- One and a half bowl undermount sink
 - Noise deadening pads
 - Easy fixing system
- More details on p189

Stainless steel



- KSC21**
- Half bowl undermount sink
 - Noise deadening pads
- More details on p190



- KSC22**
- Three quarter bowl undermount sink
 - Noise deadening pads
- More details on p190



- KSC23**
- Single bowl undermount sink
 - Noise deadening pads
- More details on p191



- KSC24**
- Single bowl undermount sink
 - Noise deadening pads
- More details on p192



- KSC25**
- Large single bowl undermount sink
 - Noise deadening pads
- More details on p192

Stainless steel



- KVC30R/KVC30L**
- One and a half bowl undermount sink
 - Noise deadening pads
- More details on p193



- KVC35R/KVC35L**
- One and a half bowl undermount sink
 - Noise deadening pads
- More details on p193

Composite



- KMG24**
- Single bowl undermount/inset sink
 - Tough and hygienic
 - Granite/quartz construction
 - Available in anthracite or graphite
- More details on p194



- KMG30**
- One and a half bowl undermount/inset sink
 - Tough and hygienic
 - Granite/quartz construction
 - Reversible
 - Available in anthracite or graphite
- More details on p194

Ceramic



- KC41**
- Ceramic undermount/inset half bowl sink
 - Fireclay construction
- More details on p195



- KC42**
- Ceramic undermount/inset single bowl sink
 - Fireclay construction
- More details on p195



KCC21
Stainless steel undermount half bowl sink

Features

- Polished finish
- Easy fixing system
- Noise deadening pads

Accessories

- Waste kit
- Plumbing pack

Optional accessories

- Stainless steel colander, AKC04
- Waste disposer, AKD01/ AKD02
- Space saver plumbing pack, PP1

Available in

- Stainless steel

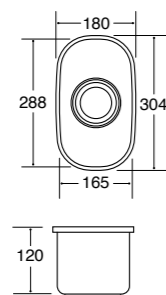

KCC22
Stainless steel undermount three quarter bowl sink

Features

- Polished finish
- Easy fixing system
- Noise deadening pads

Accessories

- Waste kit
- Plumbing pack

Optional accessories

- Waste disposer, AKD01/ AKD02
- Space saver plumbing pack, PP1

Available in

- Stainless steel

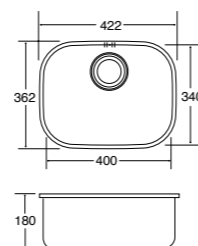

KCC23
Stainless steel undermount single bowl sink

Features

- Polished finish
- Easy fixing system
- Noise deadening pads

Accessories

- Waste kit
- Plumbing pack

Optional accessories

- Stainless steel basket, AKB10
- Waste disposer, AKD01/ AKD02
- Space saver plumbing pack, PP1

Available in

- Stainless steel

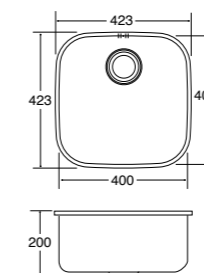



KCC24
Stainless steel undermount rectangular single bowl sink

Features

- Polished finish
- Easy fixing system
- Noise deadening pads

Accessories

- Waste kit
- Plumbing pack

Optional accessories

- Waste disposer, AKD01/ AKD02
- Space saver plumbing pack, PP1

Available in

- Stainless steel

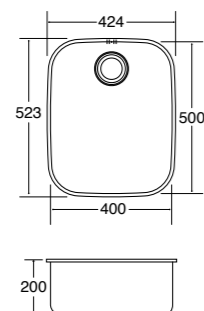

KCC27
Stainless steel undermount right-hand one and a half bowl sink

Features

- Polished finish
- Easy fixing system
- Noise deadening pads

Accessories

- Waste kit
- Plumbing pack

Optional accessories

- Waste disposer, AKD01/ AKD02
- Space saver plumbing pack, PP2

Available in

- Stainless steel

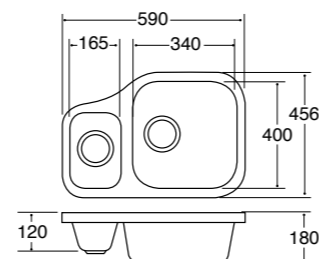

KCC28
Stainless steel undermount left-hand one and a half bowl sink

Features

- Polished finish
- Easy fixing system
- Noise deadening pads

Accessories

- Waste kit
- Plumbing pack

Optional accessories

- Waste disposer, AKD01/ AKD02
- Space saver plumbing pack, PP2

Available in

- Stainless steel

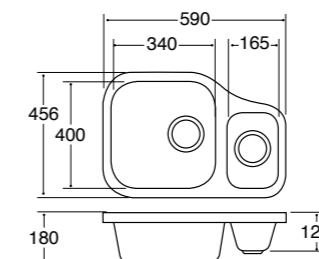



KSC21
Stainless steel undermount half bowl sink

Features

- 1mm heavy gauge stainless steel construction
- Noise deadening pads
- Square strainer design

Accessories

- Concealed overflow
- Waste kit
- Plumbing pack

Optional accessories

- Space saver plumbing pack, PP1

Available in

- Stainless steel

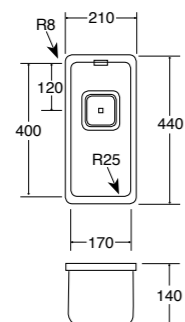

KSC22
Stainless steel undermount three quarter bowl sink

Features

- 1mm heavy gauge stainless steel construction
- Noise deadening pads
- Square strainer design

Accessories

- Concealed overflow
- Waste kit
- Plumbing pack

Optional accessories

- Space saver plumbing pack, PP1

Available in

- Stainless steel

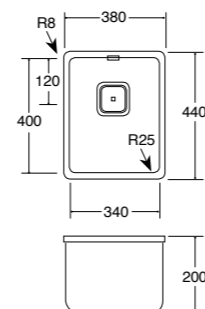

KSC23
Stainless steel undermount single bowl sink

Features

- 1mm heavy gauge stainless steel construction
- Noise deadening pads
- Square strainer design

Accessories

- Concealed overflow
- Waste kit
- Plumbing pack

Optional accessories

- Space saver plumbing pack, PP1

Available in

- Stainless steel

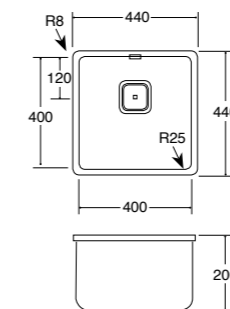



KSC24
Stainless steel undermount single bowl sink

- Features
- 1mm heavy gauge stainless steel construction
 - Noise deadening pads
 - Square strainer design

- Accessories
- Concealed overflow
 - Waste kit
 - Plumbing pack

- Optional accessories
- Space saver plumbing pack, PP1

- Available in
- Stainless steel

KSC25
Stainless steel undermount large single bowl sink

- Features
- 1mm heavy gauge stainless steel construction
 - Noise deadening pads
 - Square strainer design

- Accessories
- Concealed overflow
 - Waste kit
 - Plumbing pack

- Optional accessories
- Space saver plumbing pack, PP1

- Available in
- Stainless steel

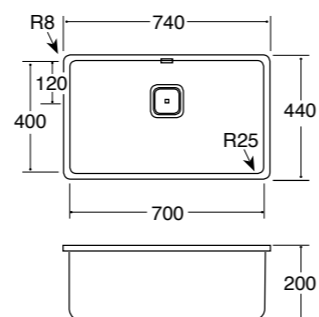
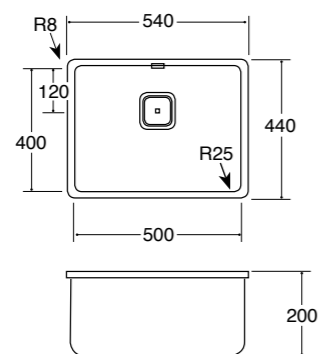

KVC30R

KVC35R



KVC30L

KVC35L

KVC30
Stainless steel undermount one and a half bowl sink

- Features
- Satin finish
 - Noise deadening pads
 - New and exclusive strainer design

- Accessories
- Concealed overflow
 - Waste kit
 - Plumbing pack

- Optional accessories
- Waste disposer, AKD01/ AKD02
 - Space saver plumbing pack, PP2

- Available in
- Stainless steel - right hand half bowl, KVC30R
 - Stainless steel - left hand half bowl, KVC30L

KVC35
Stainless steel undermount one and a half bowl sink

- Features
- Satin finish
 - Noise deadening pads
 - New and exclusive strainer design

- Accessories
- Concealed overflow
 - Waste kit
 - Plumbing pack

- Optional accessories
- Waste disposer, AKD01/ AKD02
 - Space saver plumbing pack, PP2

- Available in
- Stainless steel - right hand half bowl, KVC35R
 - Stainless steel - left hand half bowl, KVC35L

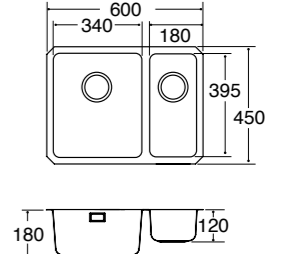
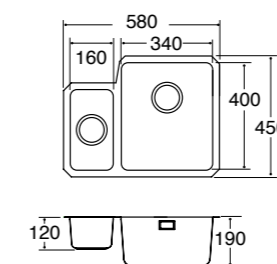



Anthracite



Anthracite



A handmade fireclay sink is very hard wearing. It is traditionally made, and each one will have individual characteristics. The dimensions may vary slightly and there are likely to be natural marks under the glaze giving real character.



Handmade fireclay sink.



Graphite



Graphite

KMG24 Composite undermount/inset single bowl sink

- Features
- Granite/quartz construction
 - Tough and hygienic
 - Super smooth metallic finish
 - Reversible
 - Fits in 600mm base unit
 - New and exclusive strainer design
 - Both undermount and inset clips included
 - Can be undermount or inset

- Accessories
- Concealed overflow
 - Waste kit
 - Plumbing pack

- Optional accessories
- Waste disposer, AKD01/AKD02
 - Space saver plumbing pack, PP1

- Available in
- Anthracite
 - Graphite

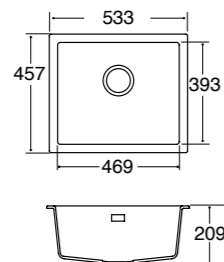

KMG30 Composite undermount/inset one and a half bowl sink

- Features
- Granite/quartz construction
 - Tough and hygienic
 - Super smooth metallic finish
 - Reversible
 - Fits in 800mm base unit
 - New and exclusive strainer design
 - Both undermount and inset clips included
 - Can be undermount or inset

- Accessories
- Concealed overflow
 - Waste kit
 - Plumbing pack

- Optional accessories
- Waste disposer, AKD01/AKD02
 - Space saver plumbing pack, PP2

- Available in
- Anthracite
 - Graphite

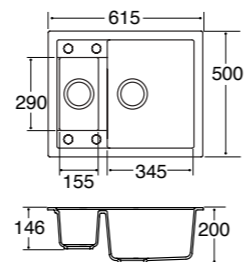

KC41 Ceramic undermount/inset half bowl sink

- Features
- Classic design
 - Fireclay construction
 - Can be undermount or inset

- Accessories
- Waste kit
 - Plumbing pack

- Optional accessories
- Waste disposer and adaptor, AKD01/AKD02 and AKD03
 - Space saver plumbing pack, PP1

- Available in
- White

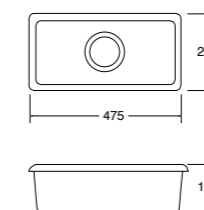

PLEASE NOTE: DIMENSIONS MAY DIFFER BY UP TO 5%

KC42 Ceramic undermount/inset half bowl sink

- Features
- Classic design
 - Fireclay construction
 - Can be undermount or inset

- Accessories
- Waste kit
 - Plumbing pack

- Optional accessories
- Waste disposer and adaptor, AKD01/AKD02 and AKD03
 - Space saver plumbing pack, PP1

- Available in
- White

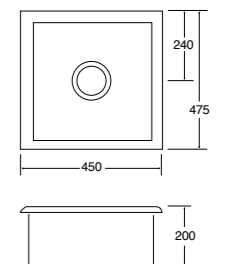

PLEASE NOTE: DIMENSIONS MAY DIFFER BY UP TO 5%

Taps

Whether it is a simple lever tap, or something more sophisticated, choose a tap from our 2018 collection and you can be sure that it will be beautifully designed.



Our range includes taps to suit every kitchen from minimalist styles in stainless steel, chrome or nickel to traditional mixer taps, filter and an instant hot water tap.

Filter tap

Our TF55 tap filters mains tap water to improve its taste, clarity and odour. Mains water is passed through a cartridge concealed under the sink and is controlled through the tap by a simple lever action.



Professional chef style taps

A pull-out spray is a useful helping hand on some of our contemporary taps. Use the spray for thorough rinsing of fruit and vegetables, for fast defrosting, to fill large vases or buckets, or for countless other kitchen jobs.



Hot water on demand

Speed up cooking and making hot drinks by installing a TH101 instant hot water tap. With an under-counter heating tank, this useful kitchen appliance can produce around 1.8 litres of hot water per minute, supporting many culinary tasks.



Quick guide to taps

The range of taps from CDA covers a wide spectrum of designs, from stylish, functional taps through to cutting-edge, contemporary designer taps to make a bold statement in your kitchen.

Flow restrictors

Where building regulations (Part G) or ECO-design requirements stipulate maximum flow rates, we offer flow reducers (ATF002/ATF003), which are designed to be fitted inside the supply tails of the tap.

Guidance on minimum operation pressure

Taps with a minimum operating pressure of 0.4Bar, or less, are compatible with low pressure hot water systems.

Check your supply pressure before purchasing taps requiring 0.5Bar or higher.

Contemporary taps



TC10
Details on p200



TC15
details on p200



TC20
Details on p200



TC65
Details on p203



TC66
Details on p203



TC75
Details on p203

Contemporary taps



TC28
Details on p201



TC31
Details on p201



TC41
Details on p201



TC55
• Available in chrome or nickel
Details on p202



TC57
Details on p202

Contemporary taps



TV7
Details on p207



TV9
• Available in chrome or black
Details on p207

Traditional taps



TT25
Details on p204



TT41
• Available in chrome or nickel
Details on p204



TT50
Details on p205



TT56
Details on p205

Pull-out taps



TC56
Details on p202



TM1
Details on p205



TM30
Details on p206

Pull-out taps



TV11
Details on p207



TV12
• Available in chrome or brushed steel
Details on p208

Filter tap



TF55
Details on p208

3-in-1 instant hot water tap



TH101
• Available in chrome or brushed steel
Details on p208



TC10
Standard single lever tap

- Features
- Single flow
 - Minimum pressure: 0.5Bar
 - 360°C spout rotation
 - Ceramic disc valve

- Accessories
- Supplied with flexible tail pipes

- Available in
- Chrome

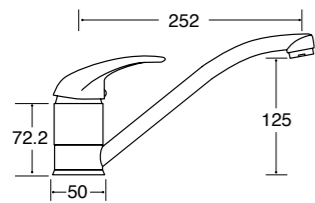

TC15
Classic single lever tap

- Features
- Single flow
 - Minimum pressure: 0.3Bar
 - WRAS approved
 - Ceramic single lever valve

- Accessories
- Supplied with rigid copper tail pipes

- Available in
- Chrome

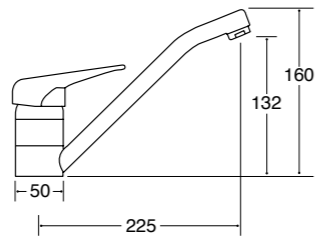

TC20
Standard quarter turn monobloc tap

- Features
- Single flow
 - Minimum pressure: 0.1Bar
 - 360°C spout rotation
 - Ceramic disc 1/4 turn valves

- Accessories
- Supplied with flexible tail pipes

- Available in
- Chrome

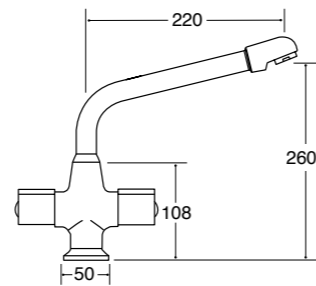

TC28
Contemporary quarter turn monobloc tap

- Features
- Single flow
 - Minimum pressure: 0.4Bar
 - Ceramic disc 1/4 turn valves
 - 360°C spout rotation

- Accessories
- Supplied with flexible tail pipes

- Available in
- Chrome

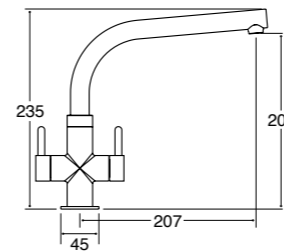

TC31
Side single lever tap with swan neck spout

- Features
- Solid stainless steel
 - Single flow
 - Minimum pressure 0.5Bar
 - Ceramic single lever valve
 - 360°C spout rotation

- Accessories
- Supplied with flexible tail pipes

- Available in
- Stainless steel

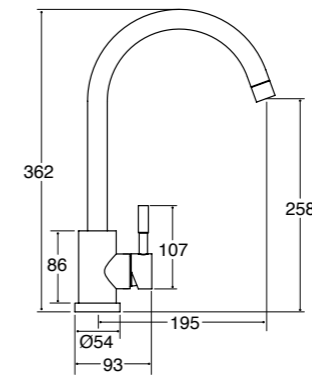

TC41
Quarter turn cross handle monobloc tap

- Features
- Dual flow
 - Minimum pressure: 0.3Bar
 - WRAS approved
 - Ceramic disc 1/4 turn valves

- Accessories
- Supplied with rigid copper tail pipes

- Available in
- Chrome

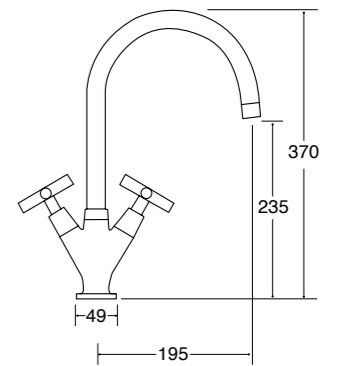



Chrome
Nickel
TC55
Monobloc tap with swan neck spout

- Features
- Dual flow
 - Minimum pressure: 0.3Bar
 - Ceramic disc 1/4 turn valves
- Accessories
- Supplied with rigid copper tail pipes
- Available in
- Chrome
 - Nickel

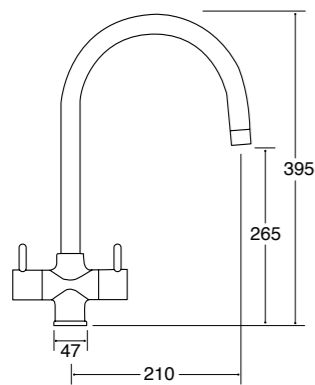

TC56
Monobloc tap with pull-out spout

- Features
- Single flow
 - Minimum pressure: 0.75Bar
 - Pull-out spout
 - Ceramic disc 1/4 turn valves
 - Hose extends up to 500mm
- Accessories
- Supplied with rigid copper tail pipes
- Available in
- Chrome

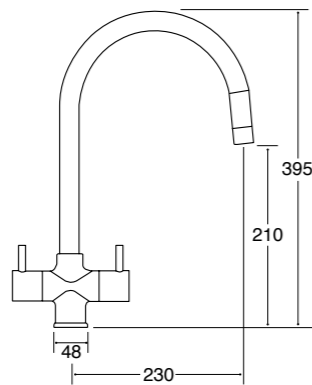

TC57
Side single lever tap with swan neck spout

- Features
- Single flow
 - Minimum pressure: 0.5Bar
 - Ceramic single lever valve
- Accessories
- Supplied with flexible tail pipes
- Available in
- Chrome

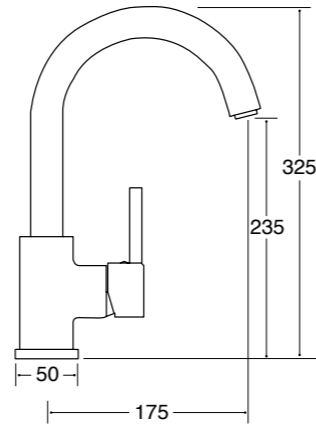

TC65
Monobloc tap with quad spout

- Features
- Dual flow
 - Minimum pressure: 0.3Bar
 - Ceramic disc 1/4 turn valves
- Accessories
- Supplied with rigid copper tail pipes
- Available in
- Chrome

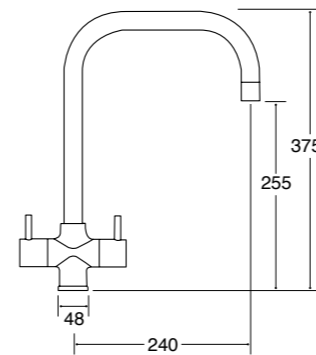

TC66
Side single lever tap with quad spout

- Features
- Single flow
 - Minimum pressure: 0.5Bar
 - Ceramic single lever valve
- Accessories
- Supplied with flexible tail pipes
- Available in
- Chrome

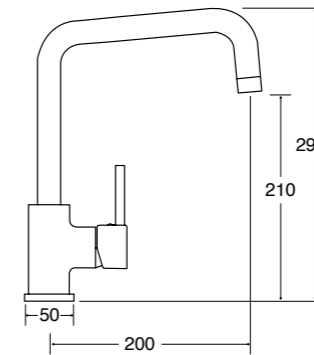

TC75
Contemporary single lever tap

- Features
- Single flow
 - Minimum pressure: 0.4Bar
 - Ceramic single lever valve
- Accessories
- Supplied with flexible tail pipes
- Available in
- Chrome

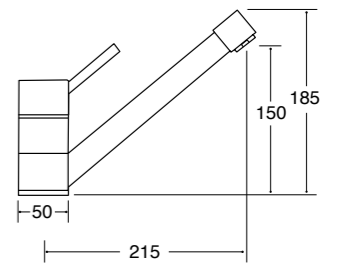



TC77
Contemporary slant monobloc tap

- Features
- Single flow
 - Minimum pressure: 0.5Bar
 - 360°C spout rotation
 - Ceramic disc 1/4 turn valves

- Accessories
- Supplied with flexible tail pipes

- Available in
- Chrome

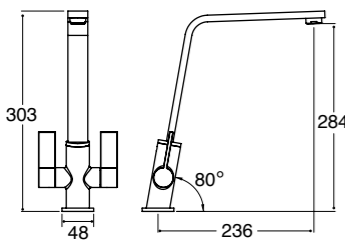

TT25
Traditional monobloc tap

- Features
- Dual flow
 - Minimum pressure: 0.3Bar
 - WRAS approved
 - Compression valves

- Accessories
- Supplied with rigid copper tail pipes

- Available in
- Chrome

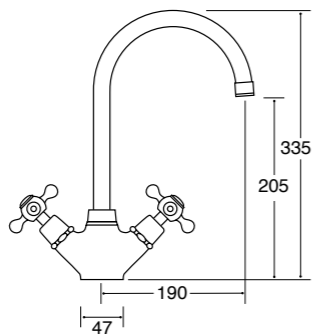

Choose white or black interchangeable handles as an optional accessory.



Chrome Nickel
TT41
Traditional quarter turn lever monobloc tap

- Features
- Dual flow
 - Minimum pressure: 0.2Bar
 - WRAS approved
 - Ceramic disc 1/4 turn valves

- Accessories
- Supplied with rigid copper tail pipes

- Optional accessories
- Interchangeable handles:
 - White/chrome, ATT01WH
 - White/nickel, ATT02WH
 - Black/chrome, ATT01BL
 - Black/nickel, ATT02BL

- Available in
- Chrome
 - Nickel

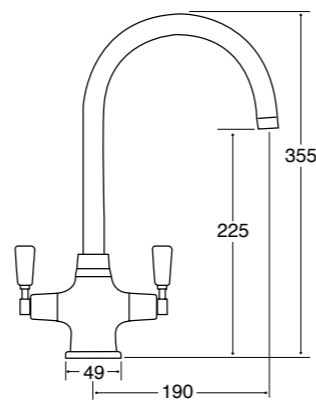

TT50
Traditional dual lever monobloc tap

- Features
- Single flow
 - Minimum pressure: 0.5Bar
 - 360°C spout rotation
 - Ceramic disc 1/4 turn valves

- Accessories
- Supplied with flexible tail pipes

- Available in
- Chrome

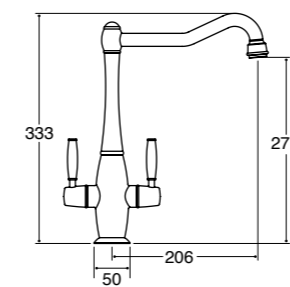

Choose white or black interchangeable handles as an optional accessory.



TT56
Traditional quarter turn bridge mixer tap

- Features
- Single flow
 - Minimum pressure: 0.3Bar
 - Ceramic disc 1/4 turn valves

- Accessories
- Supplied with adjustable inlet pipes

- Optional accessories
- Interchangeable handles:
 - White/chrome, ATT01WH
 - Black/chrome, ATT01BL

- Available in
- Chrome

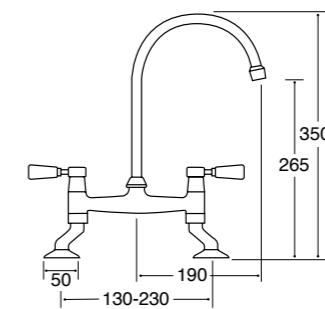

TM1
Contemporary single lever tap with pull-out spray

- Features
- Single flow
 - Minimum pressure: 1Bar
 - Pull-out spray
 - Ceramic disc valve

- Accessories
- Supplied with flexible tail pipes

- Available in
- Chrome

- Fitting note
- Please ensure that your supply pressure is adequate.

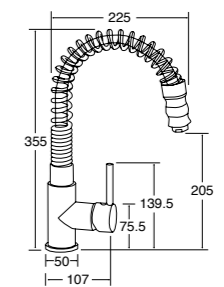



TM30
Single lever professional style coil tap with pull-out spray

Features

- Solid stainless steel construction
- Single flow
- Minimum pressure: 1Bar
- Pull-out spray
- 360°C spout rotation
- Ceramic disc single lever valve

Accessories

- Supplied with flexible tail pipes

Available in

- Stainless steel

Fitting note

- Please ensure that your supply pressure is adequate.

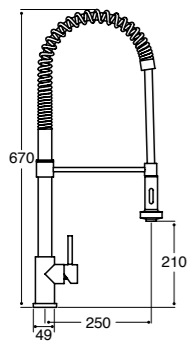

TV5
Contemporary side single lever tap

Features

- Single flow
- Minimum pressure: 0.5Bar
- 360°C spout rotation
- Ceramic disc single lever valve

Accessories

- Supplied with flexible tail pipes

Available in

- Chrome

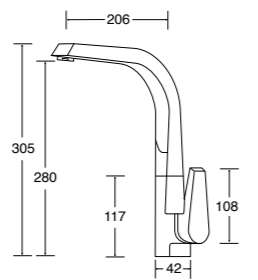

TV6
Round tower single lever tap

Features

- Single flow
- Minimum pressure: 0.5Bar
- 360°C spout rotation
- Ceramic disc single lever valve

Accessories

- Supplied with flexible tail pipes

Available in

- Chrome

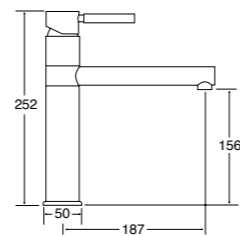

TV7
Contemporary side single lever tap with swivel spout

Features

- Single flow
- Minimum pressure: 0.75Bar
- 360°C spout rotation
- Swivel aerator for precise flow control
- Ceramic disc single lever valve

Accessories

- Supplied with flexible tail pipes

Available in

- Chrome



Swivel spout for precise flow control

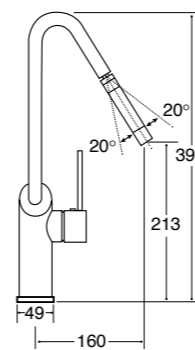

Chrome

Matt black

TV9
Contemporary square side single lever tap

Features

- Single flow
- WRAS approved
- Minimum pressure: 0.5Bar
- 360°C spout rotation
- Ceramic disc single lever valve

Accessories

- Supplied with flexible tail pipes

Available in

- Chrome
- Matt black

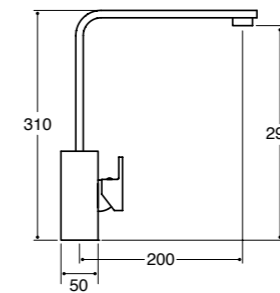

TV11
Single lever tap with black pull-out spray

Features

- Solid stainless steel construction
- Single flow
- Minimum pressure: 1.5Bar
- Pull-out spray
- 360°C spout rotation
- Ceramic disc valve

Accessories

- Supplied with flexible tail pipes

Available in

- Stainless steel

Fitting note

- Please ensure that your supply pressure is adequate.

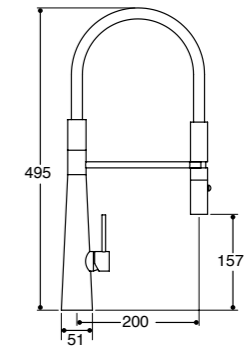



TF55
Monobloc filter tap with swan neck spout

- Features**
- Dual flow
 - Minimum pressure: 0.4Bar
 - 2 way ceramic disc valve
 - WRAS approved
- Accessories**
- Filter and installation kit
 - Supplied with rigid copper tail pipes
- Optional accessories**
- Replacement filter, ATF001
- Available in**
- Chrome
- Fitting note**
- We recommend that you replace the filter every six months.

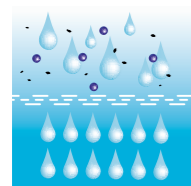

Filters the water

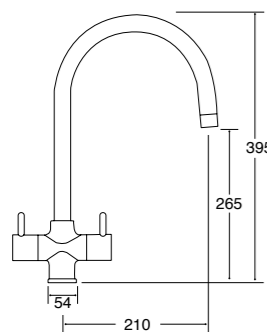

Chrome Brushed steel finish

TV12
Slimline single lever tap with pull-out spray

- Features**
- Single flow
 - Minimum pressure: 1.3Bar
 - Pull-out spray
 - Ceramic disc 1/4 turn valves
 - 360°C spout rotation
 - Ceramic disc valve
- Accessories**
- Supplied with flexible tail pipes
- Available in**
- Chrome
 - Brushed steel finish
- Fitting note**
- Please ensure that your supply pressure is adequate.

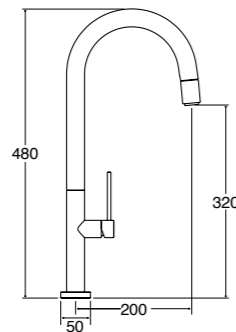

Chrome Brushed steel finish

TH101
3-in-1 instant hot water tap

- Features**
- Non-pressurised tank for increased reliability
 - Minimum pressure: 1Bar
 - 360°C spout rotation
 - 2L tank
 - Filter included
 - Rapid 12 minutes initial heat up from cold supply
 - Allows several cups of 98°C water to be dispensed
 - Easy descaling
- Accessories**
- Supplied with flexible tail pipes
 - Filter
 - Descaling solution
- Optional accessories**
- Filter
 - Descaling solution
- Available in**
- Chrome
 - Brushed steel finish
- Fitting note**
- Please ensure that your supply pressure is adequate.
 - We recommend changing the filter and descaling the boiler every six months.

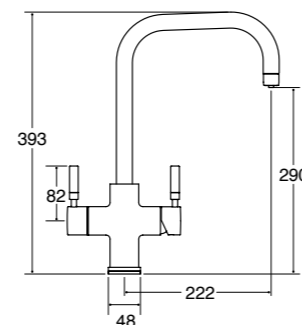

Instant hot water
Stop waiting for kettles and pans to boil. Make hot drinks instantly and speed up cooking with this useful kitchen appliance.



Oven accessories

Catalytic liner kits

Code	Contents	Compatible with
C3OL	2 side panels and 1 back panel	RV1002 ¹
C5OL	2 side panels and 1 back panel	RVC931 ¹ , RV1200 ²
C6OL	2 side panels	RV1200 ³ , DK751 ² , DK951 ²
C7OL	2 side panels and 1 back panel	DK751 ¹
C9OL	2 side panels and 1 back panel	SK381
C10OL	2 side panels and 1 back panel	DK1151, DK951 ¹
C13OL	3 piece stay clean liner kit, 2 side panels and 1 back panel for ovens with lateral halogen light	SK310, SK410



Telescopic shelf kits

Code	Contents	Compatible with
TSK3	3 shelves telescopic shelf kit	SK110, SK210, SK310, SK410, SK511
TSK4	1 shelf telescopic shelf kit	RVC931



TSK3

Recommended by CDA

When you're busy making your magic in the kitchen, that's when accidents can happen. Reduce this risk by having a professional shelving system on your oven.

Our telescopic shelf kits allow dishes to slide forward and back with ease and importantly have the strength to hold the heaviest roast.



¹main oven only. ²main and second ovens only. ³top oven only.

Please check product pages for compatibility.

Extractor accessories

AED51 125mm x 1m flexible ducting kit

- White wall outlet
- 2 cable ties
- 1m flexible hose
- Fixing kit



AED53 125mm x 6m flexible ducting kit

- White wall outlet
- 2 cable ties
- 6m flexible hose
- Fixing kit



AED54 125mm x 3m rigid ducting kit

- White wall outlet
- 2 x 1m rigid ducting
- 500mm rigid ducting
- Wall plate
- Connector
- 125mm elbow bend
- 2 threaded hose connectors
- 1m flexible hose
- Horizontal bend
- Fixing kit



AED61 150mm x 1m flexible ducting kit

- White wall outlet
- 2 cable ties
- 1m flexible hose
- Fixing kit



AED63 150mm x 6m flexible ducting kit

- White wall outlet
- 2 cable ties
- 6m flexible hose
- Fixing kit



AED64 150mm x 3m rigid ducting kit

- White wall outlet
- 2 x 1m rigid ducting
- 350mm rigid round ducting
- Wall plate
- Connector
- 125mm elbow bend
- 2 threaded hose connectors
- 1m flexible hose
- Horizontal bend
- Round to rectangular adaptor
- Fixing kit



Extractor accessories

Filters		
Code	Contents	Compatible with
CHA1	Charcoal filter (pack of 1)	CCA5
CHA4	Charcoal filter (pack of 1)	ECH61/71/91/101
CHA5	Charcoal filter (pack of 1)	CST61
CHA11	Charcoal filter (pack of 2)	EDD91
CHA12	Charcoal filter (pack of 1)	ECN62/72/92, ECP62/72/82/92/102/112, EKP90
CHA14	Charcoal filter (pack of 2)	3D9, EXA60/80
CHA15	Charcoal filter (pack of 1)	EIN60, EVA60/70/90, ECA60
CHA17	Charcoal filter (pack of 2)	EKP60/70/90, EKN60/70/90
CHA18	Charcoal filter (pack of 2)	EVX101
CHA19	Charcoal filter (pack of 2)	EDD61
CHA20	Charcoal filter (pack of 2)	EVX110
CHA21	Charcoal filter (pack of 2)	CCA7, EVG6/9, EVP61/91/101/121, EVPK90
CHA22	Charcoal filter (pack of 1)	EVPC91
CHA23	Charcoal filter (pack of 1)	EVC41, EVCK41
CHA24	Charcoal filter (pack of 2)	ECH61/71/91/101
CHA25	Charcoal filter (pack of 2)	ECHK90, ECPK90, ECR90
CHA30	Charcoal filter (pack of 2)	3S10
CHA32	Charcoal filter (pack of 2)	3U10
CHA33	Charcoal filter (pack of 2)	EVQ71
CHA34	Charcoal filter (pack of 2)	CTE61
CHA35	Charcoal filter (pack of 2)	CTE9
GRE1	Acrylic grease filter	CCA5, EIN60
GRE2M	Metal grease filter	CCA5
GRE3M	Metal grease filter	EIN60
RTP01	Re-circulating T-piece	EXA60/80

Refrigeration and dishwasher accessories

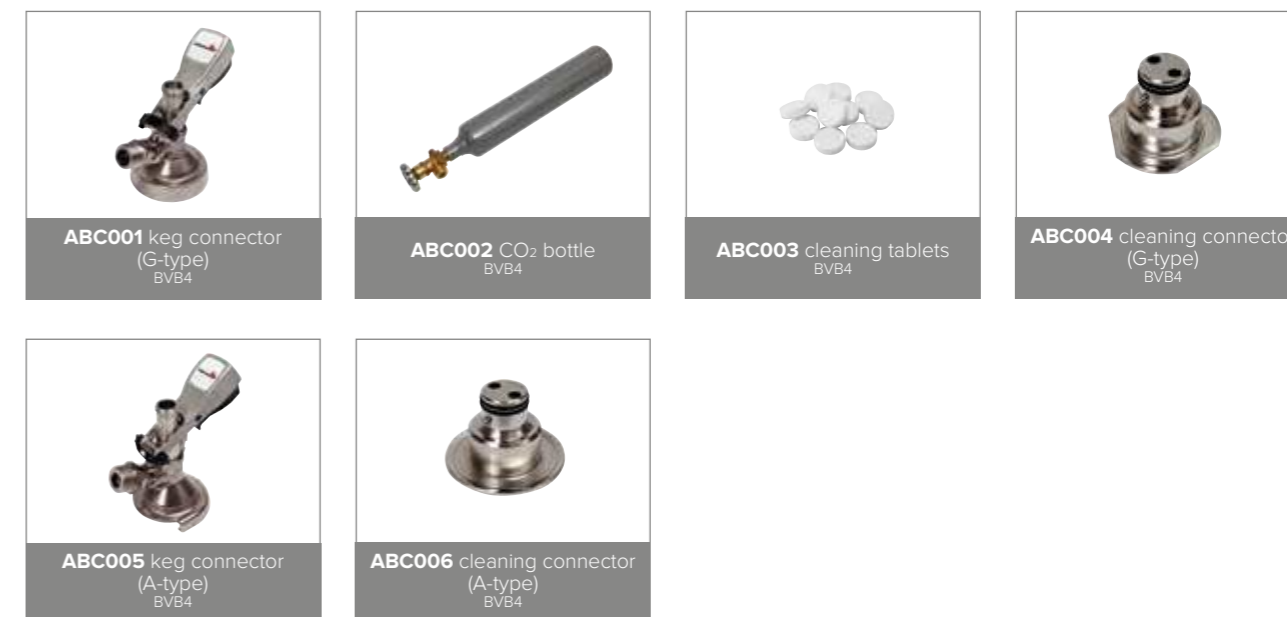

AFJ61 Joining kit

The AFJ61 joining kit contains a steel frame, plinths and joining strips to seamlessly combine the FF820, FWC861 and FF880 appliances to make the ultimate cooling station.



Wine cooler glass shelves

Code	Contents	Compatible with
AFG31	Glass shelves (pack of 3)	FWC304, FWC624
AFG61	Glass shelves (pack of 3)	FWC604, FWC861

Our wine cooler glass shelves are perfect for storing smaller items such as bottles and cans.

















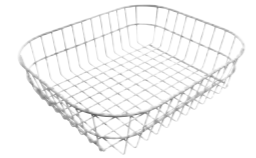

AFG31

Dishwasher wine glass holder

Code	Contents	Compatible with
AWG100	Variospace wine glass holder	WC600, WC480, WC371

Sink accessories

 AKW03 wooden chopping board KA71	 AKW05 wooden chopping board KR21	 AKW20 wooden chopping board KA20, KA21, KA22	 AKW38 wooden chopping board KA30, KA32, KA80, KA82
 AKW57 wooden chopping board KA55, KA50, KA52, KA72	 TRE wooden chopping board CCP3	 AKG80BL black glass chopping boards KG80	 AKG47 black glass chopping board KG43, KG44, KG73, KG74, KG81, KG82
 AKB05 basket KR21	 AKB10 basket KCC23	 AKB38 basket KA32, KA80, KA82	 AKB57 basket KA55, KA50, KA52, KA72
 AKC04 colander KCC21	 AKC12 colander KVL01, KVL02, KVF21, KVF22	 AKC80 colander KG80	 AKC48 colander KG43, KG44, KG73, KG74, KG81, KG82

Sink accessories

Sink accessory packs

Code	Contents	Compatible with
PA1	Wooden chopping board and stainless steel basket	AS1
PA2	Wooden chopping board and stainless steel baskets	AS2



Maximise your kitchen workstation with our sink accessory packs. Increase work space with a chopping board and keep your sink bowl looking new with a matching sink basket.



Plumbing packs

Code	Contents	Compatible with
PP1	Space saver plumbing pack	All single bowl sinks
PP2	Space saver plumbing pack	All one and a half bowl sinks

Waste covers

Code	Contents	Compatible with
AKS80	Circular waste cover	KG80

Sink accessories

Waste disposers

Code	Contents	Compatible with
AKD01	380W waste disposer	All sinks except KSC models and KC10
AKD02	550W waste disposer	All sinks except KSC models and KC10
AKD03	Waste disposer adaptor	All ceramic sinks using AKD01 or AKD02

- Easy to install
- Convenient
- Clean and hygienic
- Time saving
- Smell free
- Mess free
- Needs no regular maintenance
- Cheap to run



AKD01



AKD02



AKD03

Heating accessories

APH01SS Plinth heater

- Stainless steel finish
- 3 heat settings: cold (fan only), warm, hot
- On-off switch with neon indicator
- Automatic safety cut out
- Rated electrical power: 2kW
- Power supply required: 13A

Our 2kW slimline plinth heater provides instant heat where space is at a premium and discreet yet effective heating is required.

Cleverly concealed in the 'kick space' beneath kitchen units, stairwells and fitted furniture, a plinth heater eliminates the need for a separate radiator, allowing better use of the kitchen space.

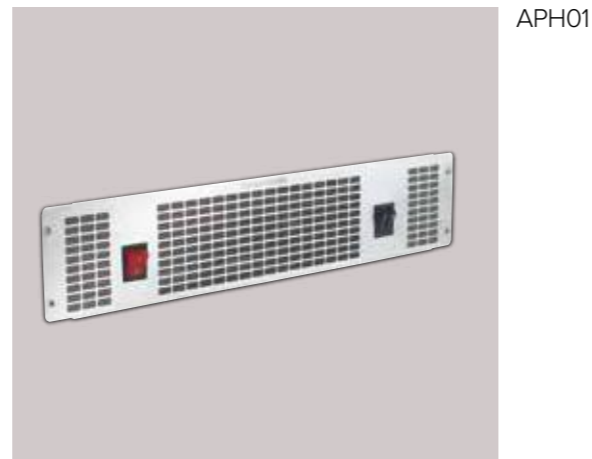

APH01

Splashbacks

Square metal splashbacks



Size	Stainless steel	Black
	Stainless steel	Black
600W x 750H	CSB6SS	CSB6BL
700W x 750H	CSB7SS	CSB7BL
900W x 750H	CSB9SS	CSB9BL
1000W x 750H	CSB10SS	CSB10BL
1200W x 750H	CSB12SS	CSB12BL

Square toughened glass splashbacks



Size	Black	Grey
	Black	Grey
600W x 750H*	ASG6BL	ASG6GR
700W x 750H*	ASG7BL	ASG7GR
900W x 750H*	ASG9BL	ASG9GR
1000W x 750H*	ASG10BL	ASG10GR
1200W x 750H*	ASG12BL	ASG12GR

*Our toughened glass splashbacks are handmade, so dimensions shown may vary by up to 5mm.

Curved glass splashbacks

Designed to match the (ECP and EKP) range of extractors.



Size	Black	Grey	Compatible with
	Black	Grey	
600W x 750H*	ASG62CBL	ASG62CGR	ECP62, EKP60
700W x 750H*	ASG72CBL	ASG72CGR	ECP72, EKP70
800W x 750H*	ASG82CBL	ASG82CGR	ECP82
900W x 750H*	ASG92CBL	ASG92CGR	ECP92
900W x 750H*	ASG92KBL	ASG92KGR	EKP90
1000W x 750H*	ASG102CBL	ASG102CGR	ECP102
1100W x 750H*	ASG112CBL	ASG112CGR	ECP112

*Our toughened glass splashbacks are handmade, so dimensions shown may vary by up to 5mm.

Curved metal splashbacks

Designed to match the (ECP and EKP) range of extractors.



Size	Stainless steel	Black	Compatible with
	Stainless steel	Black	
600W x 750H	CSB62CSS	CSB62CBL	ECP62, EKP60
700W x 750H	CSB72CSS	CSB72CBL	ECP72, EKP70
900W x 750H	CSB92CSS	CSB92CBL	ECP92
900W x 750H	CSB92KSS	CSB92KBL	EKP90

Accessories

Tap accessories

Product	Code	Compatible with
Ceramic filter	ATF001	TF55
Black tap handles	ATT01BL	TT41CH, TT56CH
White tap handles	ATT01WH	TT41CH, TT56CH
Black tap handles	ATT02BL	TT41NI
White tap handles	ATT02WH	TT41NI
Flow rate restrictors*	ATF002	All taps with rigid copper tail pipes
Flow rate restrictors*	ATF003	All taps with flexible tail pipes

*Provides 'Part G' compliance.



TT41 tap handles

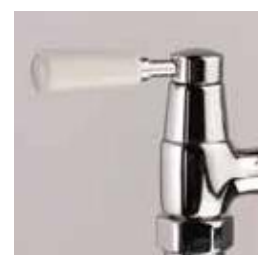

TT56 tap handles

Website

You'll find the latest news and product information at www.cda.eu.

You can also locate your nearest CDA retailer, register your purchase or contact our customer care team.

From time to time our products are changed, specifications updated and new products launched. Visit our website for all up to date information and specifications.

www.cda.eu



Guarantee

Terms and conditions of guarantee

- Parts are defined as mechanical/electrical parts only.
- Products registered outside of the 30 day period will receive 12 months parts and labour.
- Proof of date of purchase must be supplied.
- To qualify for free parts they must be fitted by a CDA appointed engineer.
- Any attempts to modify or repair an appliance by an unauthorised person will render all guarantees invalid.
- A charge will be made for attending a reported fault that transpires to be due to misuse or mis-installation.
- CDA retains the right to invalidate the guarantee in the event of physical or verbal abuse towards any member of staff.
- CDA guarantees cover domestic use only - commercial use is not covered.
- Guarantees in whole or part are not transferable.
- Taps – During the first year, at our discretion we may pay for refitting (on receipt of the faulty part/tap, once inspected and deemed faulty) up to a maximum defined cost.
- The provision of services under the guarantee neither extends the term of the guarantee nor sets in motion a new guarantee period. The guarantee period for spare parts fitted ends with the expiry of the guarantee on the appliance as a whole. The guarantee remains effective from the date of purchase.
- On the occasion that a product is over 2 years old and is considered to be beyond repair, or uneconomical to repair, then we will offer a replacement appliance and charge an appropriate monetary offset in respect of the period of use already enjoyed.
- Guarantees apply in the UK and Southern Ireland only.

What is not covered

- Transport damage for which CDA is not responsible.
- Improper installation and assembly.
- Improper use including where an appliance has been used in a non-domestic environment, or poor maintenance, or failure to observe the operating instructions.
- Faults due to accidental damage or misuse.
- Damage caused by the appliance coming into contact with unsuitable materials.
- Claims in respect of compensation for consequential loss, except where such liability is legally mandatory.
- Consumables and cosmetic parts such as glass, bulbs, seals, fuses, filters, external hoses, cosmetic parts, baskets, trays, burner caps, burner bases etc.
- Damage to, or during, the replacement of any light bulbs or removable parts of glass and plastic.
- Gas leaks not related to a CDA appliance.
- TH101 3-in-1 instant hot water tap is guaranteed for 2 year parts and 2 year labour.

Details of extended warranties are available on request.

This table shows where the guarantee is restricted due to non-domestic conditions:

	5 year parts, 2 year labour	2 year parts, 2 year labour	1 year parts, 1 year labour
Normal domestic sale and use	✓		
Rental or service apartment (non-students)		✓	
Students (communal living and non-communal) not new build		✓	
Students (communal living and non-communal) new build		✓	
Students (non-communal) one student per kitchen	✓		
Semi-commercial e.g. school domestic science lab			✓

E & O E • ALL DIMENSIONS AND ILLUSTRATIONS ARE PROVIDED FOR GUIDANCE ONLY. CDA RESERVE THE RIGHT TO CHANGE SPECIFICATIONS WITHOUT PRIOR NOTICE.

WEEE PRODUCER REGISTRATION NUMBER: WEE/FD0074UR.



For more information please contact:

The Sales Department on **01949 862010**

The Customer Care Department on **01949 862012**

www.cda.eu

The CDA Group Ltd. Harby Road, Langar, Nottinghamshire, NG13 9HY T: **01949 862 000** F: **01949 862 001** E: sales@cda.eu

Distributed in Ireland by: **Bodel Distributors**, Hulls Lane, Lisburn, BT28 2SR T: **048 9267 2412** F: **048 9267 1873** W: www.bodel.com

Distributed in Pakistan by: **Chughtaiz**, Lahore, Pakistan T: **+92 42 3578 2891 2** W: www.chughtaiz.com